



PAKISTAN
ENGINEERING
COUNCIL

Magazine

July 2014

**CREATES AND PROMOTES
SUSTAINABLE ENERGY SOLUTIONS**



Setting New Milestones



Solar tubewell



Waste Water Treatment



Assembly line



Men at Work



Desert Water Schemes



Solar Water Plant

Pak Oasis is a market leader in providing affordable, innovative and sustainable water solutions in Pakistan. At Pak Oasis our team of more than 3000 dedicated professionals are working day and night to provide uncompromising safe and healthier water footprints. Our resolve is to bring prosperity to life, provide employment, train rural youth and keep exploring more environment friendly ways in delivering cutting edge water solutions of global standards wherever we operate.

Pak Oasis is a Member and Partner of



contents

JULY 2014



Chief Patron

Engr. Syed Abdul Qadir Shah
Chairman (PEC)

Editor-in-Chief

Engr. Mukhtar Ali Sheikh
Vice Chairman PEC (Sindh)
Convener, PR Committee

Editorial Board

Engr. Mohsin Ali Khan
Member PR Committee

Engr. Habib Ahmed

Member PR Committee
(Coordinator UAE)

Sub-Editor

Mahmood Rehmani
Public Relation Officer

Public Relation Committee

Engr. Mukhtar Ali Sheikh (Convener)
Engr. Col (R) Syed Zafaruddin Ahmad
Engr. Muhammad Nasrullah
Engr. Abdul Ghaffar Tahir
Engr. Syed Abrar Ali
Engr. Moien Ahmad Khan
Engr. Muhammad Yousuf
Engr. Rashid Ahmed
Engr. Syed Waqar Hussain
Engr. Pervaiz Younasi
Engr. Abdul Aziz Bhutto
Engr. Habib Ahmed
Engr. Mohsin Ali Khan
Engr. Manzoor Ali Shaikh
Engr. Javed Safdar
Engr. Abdul Majid Malik
Engr. Samreen Abid

07 Message S. Vice Chairman (Sindh)

08 Message from Editor

09 UAE Visit

- a) Dinner for PEC Delegation at Hilton Hotel
- b) Lunch by Business Community in Abu-Dhabi
- c) International Water Conference Dubai

15 Pictorial Gallery

21 Activities of PEC

27 University Corner

31 Interviews

40 Articles of Engineers

85 Views/Opinions

With Compliments from

Public Relation Committee
Pakistan Engineering Council
Ataturk Avenue (East) G-5/, Islamabad.
Tel : 051-111-111-732
Fax : 051-2276224
URL: www.pec.org.pk

MAGAZINE CIRCULATION 50,000

For feedback & comments

sheikhmukhtar@hotmail.com, engrhab@gmail.com
makhan613@gmail.com, pr@pec.org.pk



We build our Success brick by brick

Confidence, trust and credibility.
That's what we, at Abdullah Group, have been building
one successful project after another with.

Today, Abdullah Group is currently working on
many projects in Qasimabad Hyderabad.
This translates into thousands of beautiful homes
and living communities, as well as world-class
commercial and retail developments.

Quality Construction | On-time Delivery
High-end development | Solid investments with Guaranteed Growth



Abdullah Builders & Developers

Abdullah Chambers, Opposite Faran Hotel, Saddar, Hyberabad,
Tel: (022) - 2654580, 2780363

www.abdullahgroup.com.pk



<http://www.facebook.com/abdullahgroup>



*Message From
Engr. Syed Abdul Zadir Shah
Chairman, Pakistan Engineering Council*

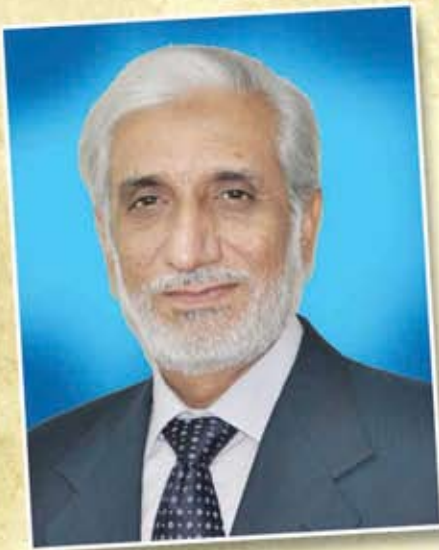

My dear Engineers as you know that PEC is a statutory, regulatory body of Engineers in Pakistan and have to set and maintain realistic and internationally relevant standards of professional competence and ethics for

Engineers and shall

function as an apex body to encourage & promote Engineering profession. I am delighted to extend my views that PEC is playing its role in identifying opportunities for our Engineers. In recent times Pakistan Engineering Council organized 5th World Engineering Congress at Islamabad. 1st International Young Engineers Convention at Lahore and have organized 131 seminars, workshops across the Country within one year. Besides this some important gatherings have been organized in Karachi, Quetta, Peshawar, Hyderabad and Sukkur to provide opportunity to the Engineers of these areas to interact.

Fellow Engineers, you will be glad to know that PEC took the first ever practical step to explore the opportunities of development for our Engineers across the borders. Let me share that in this connection a high powered delegation of PEC visited UAE where enormous projects have been planned to be launched on account of Expo 2020 in Dubai worth \$ 50 Billion and because of FIFA 2022 in Qatar worth \$ 100 Billion and more than \$ 300 Billion under Economic Vision 2030 will be completed in UAE and Qatar within coming 15 years. For which more than 30,000 Engineers are required.

Notwithstanding, MOUs were signed with CEO Club (known as Trillion Dollar Club) and M/s Stanton Chase International the leading development firm in the world. H.E Ambassador of Pakistan Mr. Asif Durrani hosted a dinner for the delegation on 22nd March with the support of few prominent Engineers including CEO of Drill Tech Engr. Zahir Awan. It was the largest ever gathering of Engineers under one roof in UAE. The Engineers extended warm welcome to the delegation and in reply to their demands I on behalf of PEC assure them of full support and committed to open PEC Liaison Office in UAE/Dubai so that effective measures can be taken to tap the opportunities arising in the region.

The business community of Pakistan in Abu Dhabi also arranged a lunch in honor of PEC delegation on 23rd March.

The Pakistan day sponsored by PEC was celebrated in Abu Dhabi organized by Pak Embassy was attended by Excellence Ambassadors of 13 Countries and was also honored by Prince H.H Mubarak and other delegations followed by Dinner.

Pakistan Engineering Council has planned to organize a job fair at Karachi which will provide an opportunity to our Engineers for initial contact with recruiter and will lead to a job interview. Fellow Engineers attend this job fair and extend this message to all your colleague Engineers to participate and get optimum benefit

In the end, I would like to express that our Engineers must lead this age of industrial revolution. I have no doubt that Pakistani Engineers have the capacity and will to fulfill this role.

May Allah (SWT) bestow vision and strength to our Pakistani Engineers in proper contribution towards development and progress of our country & regions as a whole.

*Message From
Engr. I.A. Osmani
Senior Vice Chairman, Pakistan Engineering Council*



I would like to draw the attention of young engineers who have completed their engineering graduation in recent years towards the need to understand the role and functioning of Pakistan Engineering Council. It has been observed that many of the young engineers are ignorant of the structure, composition and functioning of PEC and the role of an individual engineer in its interventions. The young engineers are advised to read the PEC Act 1976 through which the Council was established and other related Byelaws which are available on website (www.pec.org.pk). Every engineer is a building block for PEC and has a role to play. Young engineers need to understand the Continuing Professional Development program and should participate with zeal and zest in short courses and seminars arranged by PEC itself and by its registered Professional Engineering Bodies. This program is linked with international recognition and mobility of our engineering graduates in getting job, at PEC's JobShop portal on www.pec.org.pk job advertisements and CVs of unemployed engineers are regularly uploaded. Young engineers are especially obliged by PEC to start their own construction firm and they

are awarded with a higher registration category based on their qualification. Engineering consultants are advised to align themselves with international standards and should participate in international level projects. PEC will facilitate and support PEC registered consultants to take advantage of constancy opportunities in other countries.

*Message From
Khadim Hussain Bhatti
Secretary/Registrar, Pakistan Engineering Council*



All over the world the engineers are highly valued professionals as the engineering profession propels the economy of any country. Pakistan Engineering Council is well aware of the needs for the development of engineering profession in the country. Realizing the importance of international recognition of engineering qualification, cross mobility of our engineering graduates and to provide them access to international job market, PEC has achieved memberships of various international bodies which reflect that our engineering qualification, standards and process of accreditation is being recognized internationally.

For the professional growth and skill development of engineers, PEC regularly conducts short courses, seminars and workshops on different topics throughout the country and has also registered Professional Engineering Bodies (PEBs) to impart such activities.

For the practice of engineering profession in the country PEC is facilitating the Engineers, Consultants, Constructors/Operators in obtaining their registration & renewal at Headquarter, Islamabad and also through Branch/Liaison offices located in all parts of the country. To safeguard the interest of member engineers, PEC is keeping close liaison with various engineering departments within the country and abroad regarding their job opportunities and to facilitate our engineers, constructors and consultants for upcoming projects.

PEC is also providing assistance to the Federal Government as a Think Tank by preparing reports, codes etc. on various engineering issues & their solutions to overcome such problems of Pakistan. PEC has become an effective bridge between Government, industry and education.

*Message From
Engr. Mukhtar Ali Sheikh
Vice Chairman (Sindh),
Convenier Public Relation Committee*



Dear Colleagues, finally Pakistan Engineering Council took first ever practical step to explore the opportunities of employment for our young engineers and of contract for our contractors abroad. At the invitation of Pakistan Embassy, Abu Dhabi, UAE a high powered delegation of PEC which included worthy Chairman PEC,

three Vice Chairmen and other senior members visited UAE from 21st to 24th March 2014. It will be pertinent to mention that occurrence of this historic visit and its subsequent success was the outcome of committed and coordinated effort of our contact point Engr Habib Ahmad; the Commercial Attaché UAE and the PR Committee the guidance of Chairman PEC.

Dear Engineers, one may think why UAE was selected for the above mentioned visit of delegation of PEC. Allow me to share those development projects of worth \$50 billion in Dubai on account of Expo 2020, \$100 billion in Qatar because of FIFA 2022 and more that \$300 billion under Economic Vision 2030 will be completed in UAE & Qatar during coming ten years. More than 500,000 jobs including over 50,000 for engineers will be created in an area of 300km radius around the capital of UAE. PR Committee of PEC was quick to understand that there was an opportunity of employment for our engineers and of contracts for our contractors. Apart from many MoUs signed during the visit, I would like to highlight just three. CEO Club is a trillion dollar club and CEOs of more than 700 companies are its members. With a view to reach out to those 700 companies of UAE in one go an MoU for mutual cooperation was signed with CEO Club. Additionally out of same token an MoU was also signed with M/s Stanton Chase; leading employment firm of the world. More than 70,000 contractors are registered with PEC, to educate them about the licensing procedure

an MoU for cooperation was also signed with a consultancy firm M/s Adams. PEC will provide them space in offices of PEC in Karachi and Islamabad. I am sure these two steps will go a long way towards national development and prosperity.

The story of visit will not be completed with out mentioning participation of delegation in Water Conference in historical Burj Khalifa. The cursey extended by M/s Pak Oasis in arranging participation in the event and hosting a grand lunch in Armani Hotel(Burj Khalifa) was a treat, which will remain in the memories of each delegate for many many years.

Fellow Engineers, presence of more than 250 engineers of Pakistan serving in Emirates in the jam packed hall of Hilton Abu Dhabi on 22nd March in the dinner hosted by H.E. Ambassador of Pakistan Mr Asif Durrani & Commercial Attaché Engr Habib Ahmad with the support few prominent engineers including CEO of Drill Tech Engr Zaheer Awan. It was the largest gathering of engineers abroad under one roof. The engineers extended warm welcome to the Chairman PEC and the delegation and showed keen interest in getting themselves registered with PEC and also requested that PEC was their mother organization too, therefore, a system may be developed whereby they could cast votes in the elections. The Ambassador of Pakistan in his address highlighted the ocean of opportunities present in the region and advised PEC to open a branch office in Abu Dhabi so that these opportunities could be tapped. The The Chairman PEC assured his support to the engineers for introduction of a mechanism whereby engineers aboroad could vote for PEC elections. He also committed opening of a branch office in Abu Dhabi so that effective measures could be taken to tap opportunities arising in the region.

Fellow Engineers, the visit was just a beginning of a new chapter, follow up actions are to be taken by my vibrant PR Committee to give practical shape to each initiative taken. We will keep you updated on the progress on the commitments made during the visits and MoUs signed. The visit to UAE is covered in detail in the following pages of the magazine. Me and my team will keenly wait for your feedback and comments.

*Message From
Engr. Mohsin Ali Khan
Editor*



It gives me great pleasure to communicate with my fellow engineers. I am glad that PEC is playing a constructive role in identifying opportunities for professional growth of engineers so that they could be motivated to serve their respective industries with commitment and confidence.

As an integral part of PEC, our registered members have found a common ground to network with not just one another but communicate on regular basis with engineering bodies and engineers in cities across Pakistan and outside this great nation of ours. In the recent times, PEC has spread its wings to share knowledge and expertise of its member engineers by travelling to India, where with its engineers, we were able to deliberate on a wide range of topics in electrical, mechanical, and material engineering, natural resources and green technology and came back better informed. In addition, in the recent times apart from holding the 5th World Engineering Congress, we have organized important gatherings in Lahore, Quetta Hyderabad and Sukkur to effectively communicate with engineers based in these cities so that their suggestions, recommendations and even grievances can be given serious thought. During our interactions with engineers here and abroad, we have always underscored the Council's efforts to establish scientific standards for engineering innovations and services to our nation. I am glad that PEC's contribution in this regard has been applauded at every forum.

To demonstrate the engineering potential of Pakistan in Emirates, PEC also hosted the 23rd March reception dinner with the support of Pakistan Embassy. More than 500 dignitaries including H.H. Shaikh Mubarik bin Nahyan participated in the event. In his welcome speech the Ambassador of Pakistan gave introduction of Pakistan Engineering Council and highlighted the role it was playing in Pakistan for promotion of engineers and engineering profession. An exhibition of ten prominent companies including DESCON, M/s Habib Rafique Pvt Ltd, M/s Engineering Associates, Indus Engineering University, M/s Pak Oasis and 3 Ws water solutions. An impressive pavilion of PEC was made at the entrance and souvenirs were distributed.

Mr Asif Durani, The Ambassador of Pakistan in UAE said "There exist a dire need of Pakistan Engineering university campuses in U.A.E, as more than 1.2 million Pakistani are rendering their professional services in different departments, the proposed campuses shall be the impetus for our engineers". He further added that "No doubt our Pakistani engineers are very skilled and proficient; I pay whole-hearted homage and encourage them to work with more zest & fervor and excel their capabilities to meet the upcoming challenges in the field of engineering".

In the meantime, PEC will continue to work towards encouraging, facilitating and regulating working of professional engineering bodies to bring about creativity and innovation as well as promote an environment of research and development. In the end, my message is to channelize all our energies towards developing our own technology base rather than surviving on borrowed technology. Therein lies our true salvation.



Engr. Ghulam Hussain is the Chief Executive of National Development Consultants (Pvt.) Ltd (NDC) and President of the Association of Consulting Engineers Pakistan (ACEP). With Master in Civil Engineering he has more than 48 years extensive and varied experience in Design, Contract Management and Construction Supervision of water

resources development, highways/expressways, airports and water supply and sewerage projects both at home and abroad.

He is Vice President for Region 6 of Federation of Consultants from Islamic Countries (FCIC) which is engaged in promoting the much needed consultancy services among the Islamic countries.

As former President of the Association of Consulting Engineers Pakistan (ACEP) in 2000 – 2001, he represented

ACEP at the forum of Technical Consultancy Development Programme for Asia and Pacific (TCDPAP) in Kuala Lumpur in April 2000 and Three Gorges mega Dam Project, China in October 2001.

Concurrently he holds the portfolio of the Vice President of Pakistan Engineering Congress. He remained member of the Central Council of IEP for three consecutive terms from 1992 to 2000. He is the author of nine (9) technical articles/papers some of which were presented at national and international seminars and others published in renowned journals

Starting his professional career in 1965 with Water and Power Development Authority (WAPDA) in Pakistan, he contributed his expertise to many projects such as Taunsa Panjnad Link Canal, Diamer Basha Dam, Neelum Jhelum Hydropower, High Head Indus Tributaries, Gomal Zam Dam, National Drainage Programme at home and Mekkah-Jeddah-Madina Expressway in Saudi Arabia and Design and Construction of Dernah Ring Road, and other infrastructure projects in Libya.

WRITING

*"Forget all the rules.
Forget about being published.
Write for yourself and celebrate writing."*

~Melinda Haynes



© Belinda Witzzenhausen 2012



PAKISTAN ENGINEERING COUNCIL

Regulating the Engineering Profession

PEC paves the road for the Engineers to Success & Prosperity

A COMBO of Events

Recruitment Test

Walk-in Interviews

Seminars on Professional Grooming

Students' Project Showcase

PEC Membership Desk

JOB FAIR 2014

By the Engineers for the Engineers

Saturday, August 23, 2014

09:00 am - 05:00 pm

Hall 6, Expo Centre, Karachi.

Book your seat to EXPO 2020

www.pec.org.pk

D-6/1, Block-4, Clifton, Karachi.

Phone: +(92-21) 35834970 Fax: +(92-21) 99250216

Email: karachi@pec.org.pk, samreen.amir4@gmail.com



DINNER HOSTED BY ENGINEERING COMMUNITY OF ABU DHABI IN THE HONOUR OF PEC DELEGATION



Welcome Address By Engr. Habib Ahmed At Dinner Hosted By Engineering Committee At Abu Dhabi

Honourable ambassador of UAE Mr. Asif Durrani graced the occasion with Nearly 300 Pakistani Engineers attending the function. It was the largest get together of Engineers of Pakistan in UAE. Mr. Habib Ahmed, Commercial Secretary said in his welcome speech that Pakistani

engineers have been playing a vital and significant role in the development of United Arab Emirates and a number of Pakistani Engineers are working in government and private organizations of UAE. Mr. Habib Ahmed also informed in detail the achievement

of Pakistan Engineering Council and companies affiliated/registered with PEC. He further said that in addition to the construction centre, there are numerous opportunities in Oil and Gas, Petro Chemical and some other sectors. He also said that we have to avail the opportunities of gaining more profit through joint ventures with UAE's public and private companies.

Chairman PEC, Engr. Syed Abdul Qadir Shah expressed his views on the occasion that PEC is comprised of engineers and contractors. The basic task of PEC is to regulate the engineering profession in Pakistan and is also working for the betterment of Pakistani Engineering Institutions. PEC is responsible to regulate/approve the laws related to engineering sector. At present, 1,50,000 engineers, more than 100 engineering institutions, 10,000 engineering organizations and 1,50,000 constructors and contractors





are registered with PEC. He also hoped that large numbers of engineer consultants will be required for construction of infra structure before Dubai Expo 2020. Pakistani Engineers will significantly contribute in the development of UAE especially for Expo 2020. He said that in Dubai, 700 new hotels, bridges, buildings, highways and basic infra structure is to be built where more than 10,000 engineers will be required. PEC will try its best to induct Pakistani Engineers abroad, especially in UAE. He also announced that PEC is going to establish its liason office in UAE through which Pakistani Engineers working in UAE can have a better liason with PEC.

Chief Guest, Honorable Ambassador, Mr. Asif Durrani said that Engineers are the real builders of the country. Engineers play an important role in the construction of buildings, bridges, dams and development projects. Talent and skill of Pakistani engineers is visible in the development

of UAE. A good number of projects in UAE have been completed with the tireless efforts of Pakistani Engineers. The said projects are praised and appreciated today. It is the proof of confidence bestowed on our engineers. He further said that 1.2 million Pakistanis are working in UAE. The children of these Pakistanis are studying in the local educational institutions. We should give the opportunity to the children of these Pakistanis by establishing Pakistani Educational Institutions of international standards. Pakistan is capable to producing wether or a from needle to fighter aircrafts. This all is being done by talented and experienced Pakistani Engineers.

The Engineers of UAE who attended this function appreciated this initiative of PEC to come and visit UAE. Prominent Pakistani Engineers Mr. Yonus Kiyani, Malik Mohammad Shahnaz and Mr. Zaheer Awan also spoke on this occasion.





MoU SIGNED WITH DIFFERENT ORGANIZATIONS

MoUs were signed between PEC and reputed organizations like General Electric, Stanton Chase International, Adam Global and CEO club networks. CEO club network is the world's largest business networking club. CEO club network has got more than 1400 companies as their member and have 12000 exclusive members worldwide. They are now called "Trillion Dollar Club."



LUNCH BY PAKISTAN BUSINESS COMMUNITY IN ABU DHABI

PEC delegation attended a lunch hosted by the Pakistan Business Council of UAE and headed by prominent Pakistani businessmen Mr. Haji Muhammad Rafiq Giga. A Pakistan Day cake was also cut that day by the honorable ambassador of Pakistan in UAE Mr. Asif Durrani. The function was attended by a large number of representatives from business community of Pakistan in UAE. Mr. Muhammad Rafiq Giga invited Pakistani Engineers and businessmen to come and work in UAE as a lot of opportunities for Pakistani Engineering Companies and Engineers due to the upcoming expo 2020 being organized in UAE. Assurance was given that people would be aided in establishing their companies in the UAE.



INTERNATIONAL WATER CONFERENCE AT BURJ KHALIFA, DUBAI



An International Water Conference was organized by Pak Oasis Industries (Pvt) Ltd. Pak Oasis brought together executives from international companies such as Dow, Granados, Veolia, officials and experts from government and industry bodies in Dubai to discuss the role of water in the alleviation of poverty in the developing world. PEC delegates found the conference very informative and appreciated the efforts of Pak Oasis to deliver clean drinking water to the poor people living in rural areas of Pakistan. Souvenirs were distributed amongst all the participants. The conference was followed by lunch in Armani restaurant.



PAKISTAN DAY CELEBRATION AT ABU-DHABI UAE

PEC sponsored the Pakistan Day Celebrations on 23rd March 2014 in Abu Dhabi in a local hotel. An exhibition was also arranged at the same venue by PEC of different Pakistani companies to exhibit the professional potential of Pakistan in Engineering Services. The participants appreciated the quality of engineering goods, material and equipment manufactured/products produced in Pakistan. Local and Foreign Engineers and Contractors visited the exhibition. The Crown Prince of Abu Dhabi His Highness "Mohammed bin Zayed bin Sultan Al Nahyan" inaugurated the exhibition and graced the celebrations with his persons. Distinguished guests from Royal family, Ambassadors of various countries and many distinguish gust from Engineering community of Pakistan and families of Pakistani's residing in UAE attended the occasion in large numbers. Students from a Pakistani school in Abu Dhabi sang national songs and performed tablos which was highly appreciated by the audience.



For feedback & comments

sheikhmukhtar@hotmail.com, engrhab@gmail.com

makhan613@gmail.com, pr@pec.org.pk

Visit of PEC Delegation to CHINA AND THAILAND

Pakistan Engineering Council has been striving for recognition of Pakistani Engineers globally through mutual recognition and bilateral agreements as well membership of various accords and professional bodies. In this connection a four member PEC delegation led by the Chairman Engr. Syed AbdlQadir Shah, visited China and Thailand. PEC being a member of the Federation of Engineering Institutions of Asia and the Pacific (FEIAP) participated in the General Assembly meeting hosted by the China Association for Science and Technology (CAST). PEC was elected member of the FEIAP Executive Council besides Australia, Japan, Malaysia and the Philippines. The delegation also had meetings with few Chinese universities through Pakistan Embassy in China. The universities showed their keen interest in recognition of their Engineering Programs by PEC and mutual collaboration with Pakistani Universities. The modalities will be formalized later on.

Furthermore, on invitation of the Ambassador of Pakistan to Thailand Dr Sohail Khan, the PEC delegation visited the Asian Institute of Technology (AIT), Bangkok and met with the President and the top management of the institute. Recognition of Undergraduate as well as Graduate level programs was discussed in detail. It was decided that PEC and HEC will be invited to develop joint proposal during the Board of Trustees meeting of AIT. The delegation also had a meeting with the counterpart Thai Council of Engineers and discussed strengthening of mutual collaboration for benefits of the two Countries. A number of other top ranking universities were also visited for the same purpose/objective of their recognition and mutual cooperation in the field of engineering and technology.



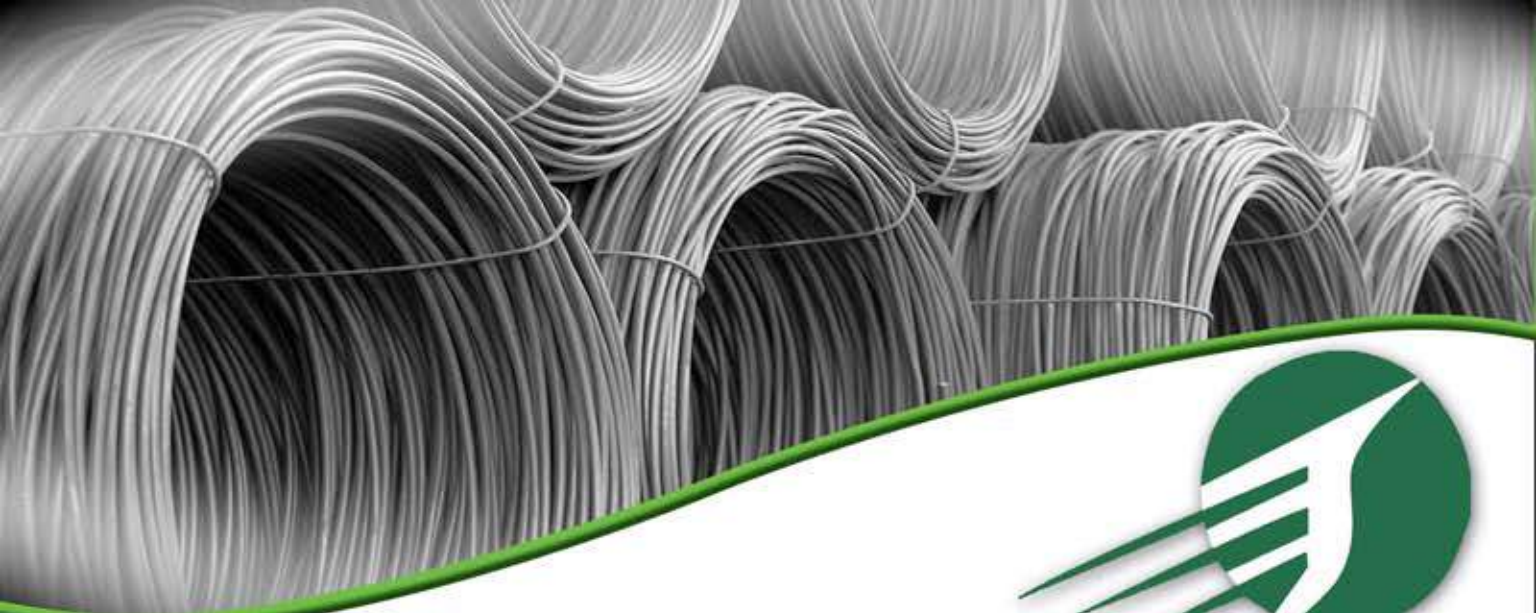

Strongwill Wire Industries Pvt Ltd.

www.strongwillwire.com

Manufacturer of PC Strand/Cotton Bale/Spring Wire

**The Most Technologically Advanced PC Strand Wire Plant in Pakistan
Based on European Technology.**

**Low relaxation strand with
the following advantages over
normal relaxation strand:**

- * Less Relaxation Loss
- * Higher Breaking Loads
- * Higher Proof Loads
- * Higher Fatigue and corrosion resistance
- * Better Performance at elevated temperature



Head Office:

Park Avenue Building, Suite # 501, 5th fl, Block-6,
P.E.C.H.S, Karachi-Pakistan. Te: +9221-34311988-89

Factory:

Plot No. 57, 39 & 40, Mouza Pathara
Tehsil Hub, Balochistan-Pakistan.



strongwillwireindustries@gmail.com



www.facebook.com/strongwillwire

19 | Pictorial
Gallery





A short course organized by PEC under Continuing Professional Development (CPD) Program at PEC HQs, Islamabad.



Chairman PEC, Engr. Syed Abdul Qadir Shah administered oath from new Governing Body Members on 16th Jan, 2014. The officials of PEC also attended the ceremony.



16th PEC Governing Body meeting held on 31st Jan, 2014 at PEC HQs Islamabad.



68th Engineering Accreditation and Qualification Equivalence Committee (EA&QEC) meeting held on 10th February, 2014 at Islamabad.

Building Energy Code of Pakistan”

Pakistan Engineering Council (PEC)



Launching ceremony of Building Energy Code of Pakistan organized by PEC, held on 14th February, 2014 at Islamabad.



PEC stall at Science & Technology Expo, held on 1-3 March, 2014 at Expo Center, Lahore.

PEC Delegation Visit to UAE



INDUSCRETE

Manufacturers of Pre-Stressed
Spun Concrete Poles

Pre-qualified by:

- * Hyderabad Electric Supply Company (HESCO)
- * Karachi Electric (K- Electric)
- * Pakistan Defence Officers
Housing Society (DHA) Karachi



Plant Location:
Karachi - Hyderabad
Super Highway
M9 Nooriabad.

Karachi Office:
I9-C, Block-6, P.E.C.H.S.,
Karachi-75400

Ph: 021-34559294, 34557012
Fax: 021-34557286, 34559293

 induscrete@yahoo.com

 www.induscrete.com

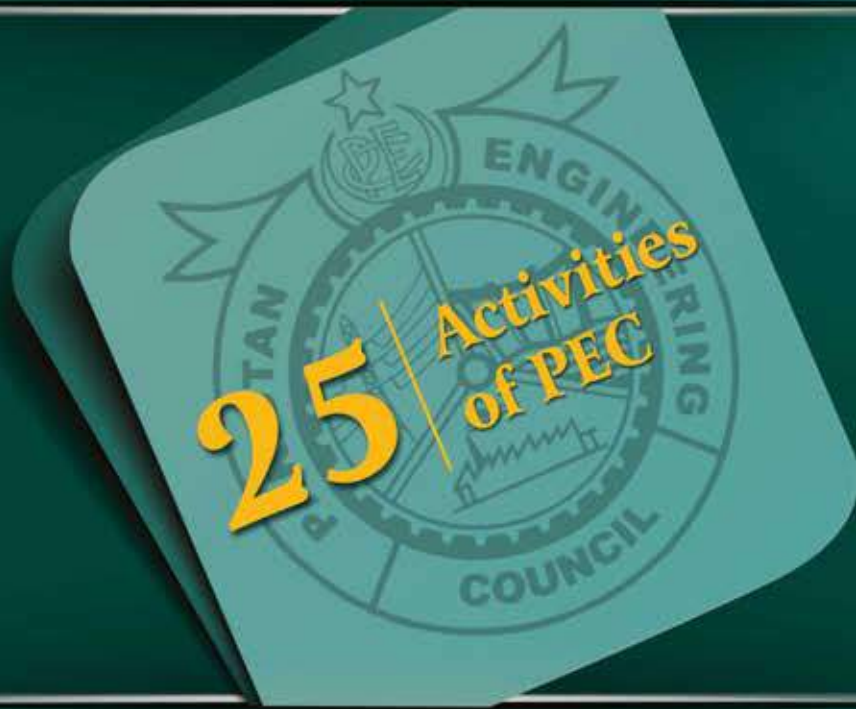

ENGINEERS

Get Together

AT HYDERABAD



The Public Relation Committee of Pakistan Engineering Council again took the lead by organizing engineers “GET TOGETHER” in April 2014 at Abdullah Sports Tower Hyderabad. The event was attended by over a thousand engineers. Honorable and respectable Chairmen Public Accounts Committee Syed Khursheed Ahmed Shah was the Chief Guest. Massive “Lucky Draw” involving innumerable prizes including Umrah tickets, Motorcycles, LED TVs, Mobile phones were distributed among the engineers through lucky draw. Chairmen Public Accounts Committee Syed Khursheed Ahmed Shah graced the occasion as Chief Guest. While addressing the massive gathering of engineers, he highlighted and appreciated the role being played by the engineers in the National Development and Growth of the country. He assured the audience that the Government was fully aware of their significance and will not leave any stone unturned in giving them a status which would be commensurate with their role in the National Development. This evening provided young engineers the opportunity to meet senior engineers and present their problems to experienced engineers in the field.





ENGINEERS DAY

A grand engineer day was celebrated at IBA Sukkar auditorium on 4th May 2014. The honorable Chief Minister (Sindh) Syed Qaim Ali Shah was the Chief Guest and Syed Khorshid Ahmed Shah, Chairman Public Account Committee and Leader of the Opposition in the National Assembly, was the Guest of Honour. Around 800 engineers attended the function. A massive Lucky Draw involving innumerable prizes including Umrah & Dubai tickets was arranged.

Detailed report will be given in the next issue of PEC Magazine.



Inauguration of PEC Liaison Office *at Khuzdar*

Pakistan Engineering Council has established its Liaison office in Khuzdar at the campus of Baluchistan University of Engineering and Technology Khuzdar. The office was Inaugrated by Engr. Ghulam Usman Babai, Vice Chairman Pakistan Engineering Council Balochistan on 6th June 2014. The Vice Chancellor, BUET Khuzdar Prof. Dr. Engr. Zahoor Baloch, Dean faculty of Engineering Prof. Dr. Engr. Mushtaq Ahmed Shah, Registrar Sher Ahmed Qambrani, Syndicate member Riaz Baloch, Liaison Officer Khuzdar Branch Engr. Sohrab Khan Bizanjo, Assistant Registrar PEC Quetta Branch Engr. Mujeeb ur Rehman, Chairmen of respective Departments, Other officials of the University and Engineers From various departments of Khuzdar were present in the Inauguration ceremony. While addressing the gathering Engr. Ghulam Usman Babai extended his thanks to The Vice Chancellor for his support in establishing PEC office at the campus of BUET

Khuzdar. He said that Liaison office at Khuzdar will facilitate the Engineers and contractors of the region in resolving their queries with PEC Registration, Renewal and issuance and renewal of licenses. The main functions of the office will include scrutinizing the applications for the registration of Professional Engineers and consulting engineers, collecting and dispatching constructors/operators cases to HQ PEC Islamabad and communicating the decisions of Pakistan Engineering Council to the local members and the verification of Engineers.

The Vice Chancellor and the other Engineers of the region who were present at the ceremony congratulated Ghulam Usman Babai and The Liaison Officer of PEC Engr. Sohrab Khan Bizanjo and appreciated the efforts of PEC in establishing the office at Khuzdar for the convenience of Engineers.



Update on PEC Karachi Branch Office Building

In order to meet the shortage of space requirement of the PEC Branch Office Karachi, the Management under the Chairmanship of Engr Syed Abdul Qadir Shah, Chairman PEC decided to construct a new building with basement, ground and 3 floors in place of existing building. The approval was obtained from the Governing Body.

A building committee was formed under the convenor ship of Engr Mukhtar Ali Shaikh, Vice Chairman (Sindh) who completed all the formalities as per PPRA Rules, for demolition of existing building, prequalification of contractors and invitation of Tenders from the prequalified contractors. The contract was given to M/S Conpro Services for Rs 68.748 million on December 2, 2013. The contractor mobilized immediately and the physical work was started on December 6, 2013.

The Architectural design and drawings were prepared by Engr I A Osmani (M/S Osmani & Company) whereas the Structural design and Drawings were prepared by Engr Arif Kasam (M/S Arif & Associates) and the construction supervision was done by Engr Ikramul Haq Siddiqui (M/S Muslim Constructors). All the above services are being provided on honorary basis. This gesture is commendable and was also appreciated by the Building Committee and the management.



The building structure has been completed now. In a recent site visit as well as in meetings, the Chairman has asked M/S Conpro Services to complete the finishing as soon as possible for which the preparations are underway by the contractor. It is expected that the entire building will be completed and ready for shifting by December 14 Insha Allah.





Starting a Construction Business Firm

- PEC provides opportunity to start a new business as a construction or operator or service provider firm for both engineers and non-engineers

Launching a Consulting Engineer Firm

- PEC also offers to set up a consulting firm in any field for engineers with 10-years experience or with master degree in engineering.
- Allied professionals may also become partner with engineers

Starting an engineering Program or Institution

- PEC encourages the establishment of new engineering program and institution to impart engineering education.

Establishing a Professional Engineering Body

- Under its Continuing Professional Development Program, for the capacity building of engineers, PEC encourages the registration of institutions and academies to conduct courses and seminars on its behalf for the engineers.

Starting a Software Development Firm

- Computer graduates and engineers may also start their own software and solution provider firm, earning business world-wide.

For details visit: www.pec.org.pk

**Call at our Helpline:
051-111-111-732**

Phone: (+92-51) 2829348,
2829311, 9206974
Fax: (+92-51) 2276224
Email: info@pec.org.pk

Pakistan Engineering Council,
Attaturk Avenue (East) G-5/2,
Islamabad

[facebook.com/pecofficial](https://www.facebook.com/pecofficial)



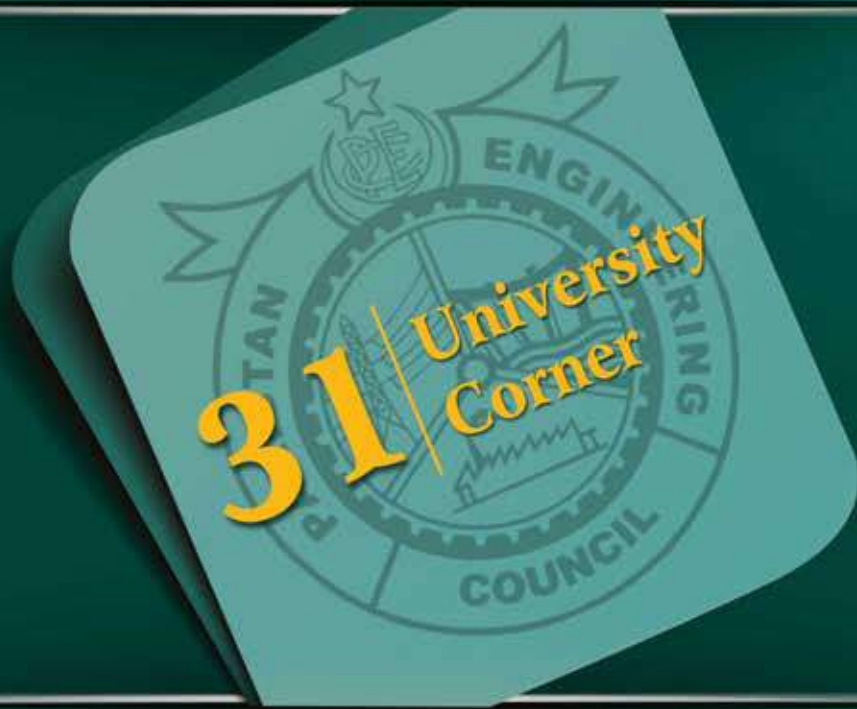



Dawood University

The foundation stone of the Dawood College of-Engineering & Technology was laid by the former President of Pakistan (Late) Field Marshal Muhammad Ayub Khan in 1962. The College was established by Dawood Foundation under the supervision of Seth Ahmed Dawood in 1964.

On March 2013 the Sindh Assembly passed the Sindh ACT No. XII of 2013, upgrading it to a University. Its academic and administrative control has been vested in the Syndicate, Senate and Academic Council as per ACT The Vice. Chanstllor as the Principal Executive and Academic Officer of the University. The University offers four year degree programs in the field of Engineering and Five year in the Field of Architecture.

The Engineering departments include Electronic, Chemical, Industrial & Management and Metallurgy & Materials. From the session 2010.2011 the University has introduced four new departments namely Fzieryg & Environment, Petroleum & Gas, Telecommunication, and Computer System Engineering.

The University has two campuses, one located near Quaid-e-Azam Mausoleum and the other situated at Block- 17 Gukhan-e-Iqbal, Karachi. These campuses comprise various facilities including class rooms, state of the art lending and reference libraries, laboratories. Workshops, drawing halls, students cafetena, auditorium, with a capacity of 650, seminar rooms, girls common room, video conferencing room.

The University has a fleet of several buses for pick and drop facility for the students. DUET has well. equipped computer laboratories. The University is situated in the heart of Karachi with access to all the Industrial zones of the city. Our students have a regular opportunity to visit industries for practical training. It is pertinent to note that with the assistance and support of the Higher Education Commission (HEC) a Video Conference room with state of the art facilities has been established under the PERK, which also provides access to the Digital Library.



“The computer services are exceptional and the long opening hours often come in handy”

Being A Chemical Engineering Student, Students have an opportunity to work on Pilot Plants.



Realizing the importance of Quality Assurance, DUET has established its Quality Enhancement Cell in November 2009 to implement quality improvement programs in all the departments and faculties of DUET under the supervision and guideline of the Higher Education Commission and QAA.

Since DUET is located in the largest industrial city of Pakistan, various Engineering Departments are directly involved in providing solutions/consultation to local industries. Students are assigned final year projects with the plant training and internship in and outside Karachi under active supervision of experts of the industry. In order to develop entrepreneurial qualities in our students and develop a base for impact based research DUET has recently established a Center for Innovation, Research, Creativity, Learning and Entrepreneurship (CIRCLE). The Center is expected to be the hub of research and also acts as an incubator for our students to enter into the world of industry and business.

BRAIN MACHINE INTERFACE FINAL YEAR PROJECT

by: Hamid Bilal
Amirah Muhammad Anwar
Muhammad Shayyan
Final Year Students

Our project is based on using brain signals and getting some useful work done out of them. A ROBO war is to be conducted using two robots. One subject is controlling his robot (slave-robot) through his brain data which has been recorded earlier and a second robot is an obstacle avoidance robot. EEG data of our group members is collected by Punjab Institute of Mental Health. For having allowed us to use their EEG machine NEUROFAX. EEG data is extracted using 16 Channels as given below:

Fp1 Fp2 F3 F4 C3 C4 P3 P4 O1 O2 F7 F8 CzFzPz Oz
Subject will try to hit the obstacle avoidance and the second robot will try to avoid slave robot, thus a ROBO war will be carried out. We had to replace the radio control interface of robot with BML.

METHODOLOGY:

EEG datasets from three healthy subjects were acquired containing the left and right hand movement information. The EEG recordings were re-referenced using the Common Average Reference technique (CAR) and then passed through FIR-filter with a bandpass range from 8 to 30 Hz to obtain alpha and beta frequency ranges which contain the motor-

cortex activity. After signal processing, epochs containing the motor-cortex activity were extracted from the datasets.

For feature extraction, Common Spatial Patterns (CSP) algorithm was used to recover motor-cortex source activity and feature vectors were calculated using log-variance method. These feature vectors were passed to a machine-learning algorithm based on Linear Discriminant Analysis (LDA) algorithm to predict left and right hand movement. When these left or right hand movements are detected, a command is generated which is sent to Arduino UNO R3 on the slave robot with the help of the Bluetooth module (BlueSMiRF). Arduino UNO R3 on Slave robot detects command sent by the computer and moves robot accordingly.

On the other hand Obstacle Avoidance robot has three IR proximity sensors of medium range. These IR sensors are at front, left and right positions. When these sensors detect something in its surroundings Arduino UNO R3 again makes a choice and move the robot accordingly.

Now when Slave robot try to strike the obstacle avoidance robot it continuously try to avoid it. Final deliverable is shown as follows:

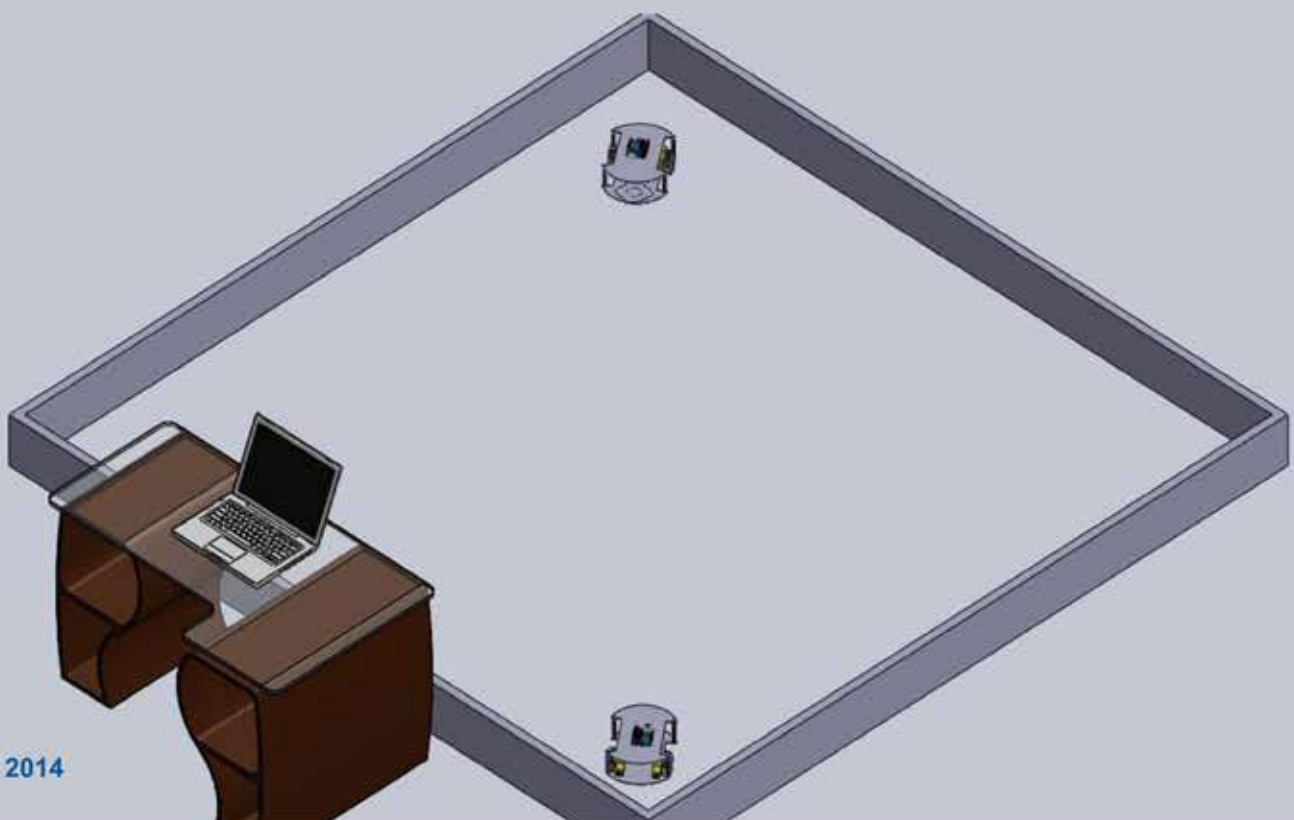

35 Interviews



“CEO” TARIQ AHMED NIZAMI

“FOUNDER & CEO” CEO Clubs Network Worldwide





Dr. Tariq Nizami is a Founder & CEO of CEO Clubs Network Worldwide having its local chapter CEO Club UAE which is one of the largest Business Networking Clubs in the world.

Tariq Nizami has education from USA with more than 30 years experience by heading an international holding company which has interest in Real Estate, Gold and Diamond, Oil, trading, Travel, Entertainment, Media, Hospitality, CEO Clubs, Network, Medical, Charitable, Institution, Fashion, Education, Financial and Information Technology.

Tariq Ahmed Nizami has received more than 20 International Awards & Appreciations including The United States Presidential Medal 1989 USA, The Medal of Honor by American Institute 1990 USA, The Beijing Real Estate Developer Award 2007, The Appreciation Certificate by Canada Government 2005, The Appreciation by Dubai Chamber of Commerce & Abu Dhabi Chamber of Commerce 2007, The California Golden State Award USA 1989, Men of Achievement Award by International Centre England 1989, The Charter Founder of Ronald Reagan Republican Centre USA 1989, The American Immigrant Wall of Honor 1992 USA, BIZ AWARD 2011 UAE, Pride of Performance Award 2011 in Los Angeles, USA., The Appreciation for Local and International Business Contribution by Minister of Foreign Trade UAE 2012 and Middle East



“ I received Last year in The Middle East ”The Entrepreneur of The Year 2012” by the GCC Chamber of Commerce & Industry, and I was additionally honored by the UAE Minister of Foreign Trade for Local and International Business contributions ”

Q. Did you always want to get in the field of business?

I always wanted to be a businessman, have successful companies all over the world. I am a creative thinker while doing business and think of new ways how to make my business better.

Q. How was your father an inspiration?

I always looked up to my father Eng. Z. A. Nizami, he was a great man, well-respected, successful in every post he worked, when he was working as a Director General of Karachi Development Authority and later Founder & Chancellor of Sir Syed University of Engineering & Technology in Karachi. Whatever I am today, all the credit goes to my parents.

Q. How do you balance personal businesses and interests in a day's work?

I am involved in multiple industries and doing good business by having a professional working team with businessmen in various countries. Prompt and timely decision making can make a business successful. I am involved in multiple businesses like Real Estate, Oil, Trading, Media, Hospitality, CEO Clubs Network, Manufacturing, Education, Information Technology and Executive Director of Hollywood Studios in USA. I have last year I received the award of “Entrepreneur of The Year 2012 Award” in Middle East by the GCC Chamber of Commerce & Industry. I was honored by the UAE Minister of Foreign Trade for Local and International Business contributions. I am privileged to have received more than 20 International Awards & Appreciations including the United States Presidential Medal 1989 in the US and Real estate Award in China and I have been a key speaker in UN conference in China.

Q. What are some challenges you faced as the CEO of CEO Clubs?

When we were growing internationally we introduce a new concept in different business cultures around the world like in China, Greece and Saudi Arabia and even in The UAE. We are always looking for new initiative and we have launched a CEO Clubs TV Channel and CEO Clubs Mobile Application and we are working for lot more in the coming years.

Q. How did you overcome those challenges?

We managed because we FOCUS on one thing, how to connect our exclusive business network worldwide by bringing business to the country and we did exactly that we grow our network which made us successful in each country's government and private sector.

Q. How do you help the youth of Pakistan?

Our Youth of Pakistan is our future and can take the country in a better direction with innovation and technology. Pakistani engineers especially have a lot of talent and expertise that's why they are all over the world holding prominent positions in their professional fields. We at CEO Clubs always look for new young CEOs who can bring new business ideas. That is the reason why we in CEO Clubs will be launching a CEO Fund for young entrepreneurs to assist youth in Pakistan.

Q. Why did you decide to live in UAE?

Living in USA for more than 30 years needed a change and being involved in Real Estate brought me to UAE in 2004 and once I saw how many opportunities plus tax free business environment that is present here, it made me move my Head Office to this beautiful and friendly business place Dubai.

Q. What has your experience been like in UAE compared to other places in the world?

Dubai is the hub of networking and for CEO Clubs it gives the chance to meet over 150 nationalities who live here in a friendly environment; through Dubai I have grown my network more than 300 % in last 8 years. Dubai is the city that never sleeps and always ready to talk business 24/7.

Q. What advice would you give as an aspiring businessman who hopes to get to where you are one day?

My advice to all businessmen is to be FOCUSED in your life and business. Focus is a very strong word which means Follow On Course Until Successful.

Q. What are some of your responsibilities as the CEO of the CEO Clubs Network?

I have a big responsibility as CEO to make sure the business opportunities are always floating and keep in touch with the new innovation plus technology as they play a key role in current business. Time is the most important thing in our life, make proper use of it. I always have this motive in my mind, to work for future opportunities.

Q. What motivated you to launch CEO Clubs?

My mission was to allow the CEO Clubs to create a nurturing environment for CEOs dedicated to improving the quality and profitability of their enterprises through shared experiences and personal growth strategies. CEO Clubs is a strong business networking club and only CEOs and top Executives can join allowing our members to benefit from more than 14,000 CEOs all over the World.

Q. What do you feel are the prospects for new Pakistan businesses who want to shift their base in Dubai?

Pakistan business man in Dubai can take advantage of the growing Hospitality industry and retail environment plus a distribution hub for GCC, Africa and Europe. CEO clubs have brought more than US \$ 500 million dollars business into UAE and we will try our best to bring and bridge the business into Pakistan from its exclusive network worldwide.

Q. In terms of business opportunities, where do you see Dubai in 5 to 10 years?

In the next 5 to 10 years, there are more than 25 billion dollar business opportunities in all sectors especially in construction and service industry as they need to build a city for projects like EXPO 2020 and Football event in the region. With the announcement of World Expo 2020 in Dubai, it should bring a lot of opportunities for PEC and its members firms whereas these opportunities should be clearly identified and jointly pursued by CEO Clubs.

Q. The CEO Club is already the world's largest association for CEOs and entrepreneurs; what are your further ambitions for the organization?

Definitely CEO Clubs has plans for growing the CEO Clubs Network in major countries, with more business involvement in emerging markets through our network's new financial sector. The two continents we are looking to have a bigger presence and expand more in are South America and Africa



CEO Clubs is a strong business networking club and only CEOs and top Executives can join allowing our members to benefit from more than 14,000 CEOs all over the World.

with continuation of educating CEOs all over the world. As per our plan, I will be more satisfied when CEO Clubs Network hits the New York Stock Exchange. In the coming year CEO Clubs Network is going into the financial side with some key brand collaboration. Lastly, my message to all the CEOs, "In life, we all make mistakes, never intentionally, but these affect personal and business decisions as well. So what we should all practice in life is to learn from the past business mistakes for a better future in business."

I am very thankful to the Pakistan Engineering Council Chairman, all Vice Chairman's, Board Members and PR Committee members for meeting us in their visit to UAE and giving the opportunity to serve my country with their support. CEO Clubs will do its best to promote Pakistan engineers and business opportunities for its contractors.

QMobile

NOIR
QUADCORE
A600

Intensely **Irresistible!**



Rs.
19,500/-

1.2 GHz
QUADCORE

 **5" HD**
LCD Display

 **4.2**
Jelly Bean

 **8MP**
Auto Focus Camera

Belief in Combination of ART TECHNOLOGY



with Human Expertise

Omar Abbas Jilani

is among Pakistan's few visionary business leaders who believes in combining state of the art technology with human expertise to provide business solutions for masses. An MBA. As Chairman of Pak Oasis (Pvt.) Ltd., he has led a dedicated team working with a vision to offer economically viable and environmentally-sustainable water and wastewater treatment solutions to people irrespective of where they live.

Q: Please take us to the phenomenal growth of Pak Oasis (Pvt) Ltd?

I am pleased to say that since its establishment in 2004 it has been providing access to clean and safe drinking water and sanitation facilities for the people of Pakistan. Pak Oasis Industries (Pvt) Ltd. has grown rapidly as one of Asia's and the Middle East's leading turnkey water solutions providers, specializing in water filtration, sanitation systems and disaster relief. What started off as a company with just four desalination plants installed in Tharparkar Desert, Sindh, has today become Pakistan's largest water engineering company with hundreds of plants varying in production capacity from tens of thousands of gallons per day to millions of imperial gallons per day. Within a short span of 9 years, Pak Oasis has carved a niche for itself by attaining national and international acclaim as an expert in water treatment for developing countries and is in the process of utilizing this expertise developed in Pakistan to assist other countries facing similar water problems. Fulfilling its commitment to producing the highest quality of purified water, the company makes use of the best equipment and products with the help of its international collaborative partners.

Pak Oasis strives to be a better company, sharing the concerns of the society and dedicating its capabilities, resources and people to creating a sustainable future.



Q: What type of solutions are offered by Pak Oasis (Pvt) Ltd.?

At Pak Oasis, we employ industry-leading membrane filtration technology, which ensures that all our water is safely purified, in accordance with both the respective national and international regulations. As a result, our water is free from the presence of harmful and undesirable microorganisms and chemicals. Our aim is to provide our customers with technology that is safer, at a lower cost and that is more efficient.

Q: Please elaborate on a number of solutions provided by your Company?

We are involved in ultrafiltration, a pressure-driven membrane separation process that removes suspended or particulate matter (including colloids and silt) from the water. We are also engaged in nanofiltration (NF) which is used to soften water because harness rejection is over 90%. NF has various applications including nitrate approval, wastewater approval esp, in laundries and removal of pesticides from surface or underground water.

On the other hand, we are also involved in reverse osmosis technology for reduction in the salt content. Reverse osmosis technology has become an extremely cost-competitive method of desalinating water as a result of falling membrane costs and economies of scale. Considering the importance of proper wastewater management due to dwindling natural water resources and rising energy costs, it is necessary to reduce, reuse and recycle this most precious commodity wherever possible. Our highly skilled engineers tailor solutions to the needs of our clients with an array of techniques to treat all types of wastewater and to ensure the proper discharge of the treated effluent into the environment.

Q: Is Pak Oasis playing any role in disaster relief?

Yes, considering that access to safe water can be one of the major issues people face in the wake of a natural disaster. At Pak Oasis, we aid governments, NGOs and private companies

to act swiftly and decisively when disaster strikes. We hold a large stock of inventory so that larger containerized systems can be fabricated and shipped out in a very short period of time.

Q: How important is innovation in the business you are in?

The importance of continuous innovation connecting it with principles of sustainability can hardly be overemphasized. Innovation helps us address many of the world's most challenging problems such as the need for clean water, renewable energy generation and increasing agricultural productivity. In the interest of operating in an environmentally friendly manner, avoid depletion of the earth's fossil fuels and solve the problem of electricity shortfall, the company is using renewable solar energy as an alternative. Pak Oasis is progressively working to provide the most economical and viable solutions to people living in deserts, coastal regions and villages. Solar energy will not only provide people with economical and sustainable energy alternative but it will also produce drinkable water out of saline water, particularly in interior Sindh. It is the job of our Research and Development department to examine technical, social and environmental innovations available in the market to develop new value added solutions. Our research team is regarded among the best in Pakistan and has received wide spread recognition for developing affordable water solutions for the underprivileged people of Pakistan.

Q: Corporate Social Responsibility (CSR) is now an important ingredient of every company's business model. Describe the initiatives that Pak Oasis has taken in the area of CSR

We believe that taking the extra step to be socially responsible does not hold us back but sets us apart from those who do not believe this policy. Pak Oasis strives to be a better company, sharing the concerns of the society and dedicating its capabilities,

resources and people to creating a sustainable future. The company is involved in community development in areas of health, education and employment of locals in the area. It also promotes skill development through apprenticeship programs and makes donations for national causes.

Pak Oasis has provided and operates dozens of water purification plants, which supply neglected populations with water treatment facilities. We are working in places including Lal Shahbaz Shrine, Sehwan; Abdullah Shah Ghazi Shrine, Karachi; Saint Laurence School, Karachi; Shrines of Benazir Bhutto; City Court of Karachi; High Court of Sindh; Shahdadt Water Filtration plant; Sukkur and Khairpur jails.

Recent floods in Pakistan posed huge problems, with over 5 million people forced to flee their homes. Collaborating where possible to help support those in crisis, Pak Oasis had, within 10 days, provided 100 Tube wells, storage tanks and fast-tracked infrastructure for 40 'rapid RO' plants for flood-affected people,

energy to make a difference in people's lives.

Q: What role can Pakistan Engineering Council in grooming engineers for nation building?

PEC has effectively played its part for the engineering profession in the country by identifying opportunities for individual growth of engineers which can eventually lead to motivated engineers contribute towards nation building. PEC also needs to develop a public-private partnership whereby it can collaborate with public and private sector organizations to mobilize resources for imparting latest technology to its members and other engineers in local and foreign institutions as well as initiating training programs and workshops in some of the finest universities in the world. Such steps will help to create engineers with a vision that goes beyond their text books.

Q: What is your Company's goal for the future?

The company's goal is to broaden the horizons of its operational activity locally as well as globally through utilization of its

Our highly skilled engineers tailor solutions to the needs of our clients with an array of techniques to treat all types of wastewater and to ensure the proper discharge of the treated effluent into the environment.



supplying 16 million litres in 12 flood-affected districts. The use of all this was supplied free of charge. Pak Oasis also freely provided eight UF plants, each with a capacity of 50,000 gallons per day, to displaced population.

Q: Human Resources is perhaps the most valuable asset of every organization. Describe human resources in your organization.

Pak Oasis is run by a team of people with decades of combined experience in the water industry. This cumulative experience helps us in understanding both the client's needs and the problems posed by the environment and circumstance, culminating in our ability to engineer the best possible solution for our customer. Be it HR, Marketing, Technical or retail, we have individuals with vast experience of these functional areas as well as young engineers and managers with tremendous

innovative technology and human resource expertise to provide safe and clean drinking water in regions where it is a scarce commodity. Pak Oasis is proud to state that its investment in technology and manpower deployment has paid huge dividends nationally and internationally.

Pak Oasis international operational activities are based in UAE. This has enabled Pak Oasis to renew, develop and focus its brand positioning, its corporate operations and its global network within the wider water industry. Pak Oasis has also used its unique position as a South Asian organization in the Middle East to attract attention to the needs of the underprivileged for easy access to clean drinking water. The company has taken initiatives towards protecting the environment by integration of renewable energy sources in its existing and newly built plants. Pak Oasis has proudly set up Pakistan's first ever completely solar powered Ultra Filtration Plant in Pakistan.

BERGER

Trusted Worldwide

jeenay ke rang



www.berger.com.pk



www.facebook.com/berger.pak



www.twitter.com/BergerPakistan

For Free Color Advisory
111-BERGER (111-237-437) KHI, LHR, ISB.



45 Articles of
Engineers

What is :

SCIENCE EDUCATION?

by: Syed Waqar Hussain



SCIENCE

Science is the systematic enterprise of gathering knowledge about the universe and organizing and condensing that knowledge into testable laws and theories. Science extends and enriches our lives, expands our imagination and liberates us from the bonds of ignorance and superstition. Adherence to these principles provides a mechanism for self-correction that is the foundation of the credibility of science.

SCIENCE EDUCATION

“Science education is the field concerned with sharing science content and process with individuals not traditionally considered part of the scientific community. The target individuals may be children, college students, or adults within the general public. The field of science education comprises science content, some social science, and some teaching pedagogy. The standards for science education provide expectations for the development of understanding for students through the entire course of their class-12 education. The traditional subjects included in the standards are physical, life, earth, and space sciences.”



Science Education Scope

Why science? – An individual perspective

In science, we can observe an ecologist observing the territorial behaviours of bluebirds or a geologist examining the distribution of fossils or a chemist observing the rates of one chemical reaction at a variety of temperatures or a nuclear physicist recording the results of bombardment of a particular kind of matter with neutrons. They are all what we call “scientists”.

So why are all these people described above doing what they're doing? In most cases, they're collecting information to test new ideas or to disprove old ones. Scientists become famous for discovering new things that change how we think about nature, whether the discovery is a new species of dinosaur or a new way in which atoms bond. Many scientists find their greatest joy in a previously unknown fact (a discovery) that explains something previously not explained, or that overturns some previously accepted idea.

Why Science? - The Societal Perspective

The answers lie in the desire to improve people's lives. Geneticists trying to understand how certain conditions are passed from generation to generation and biologists tracing the pathways by which diseases are transmitted are clearly seeking information that may better the lives of ordinary people. Earth scientists developing better models for the prediction of weather or for the prediction of earthquakes, landslides, and volcanic eruptions are likewise seeking knowledge that can help avoid the hardships that have plagued humanity for centuries.

Moreover, societies support science because of simple curiosity and because of the satisfaction that comes from knowledge of the world around us. Few of us will ever derive any economic benefit from knowing that the starlight we see in a clear night sky left those stars thousands and even millions of years ago, so that we observe such light as messengers of a very distant past. However, the awe, perspective, and perhaps even serenity derived from that knowledge is very valuable to many of us. When intangible benefits like these are combined with the more tangible ones outlined above, it's no wonder that most modern societies support scientific research for the improvement of our understanding of the world around us.

Science and Change

If scientists are constantly trying to make new discoveries or to develop new concepts and theories, then the body of knowledge produced by science should undergo constant change. Such change is progress toward a better understanding of nature. It is achieved by constantly questioning whether our current ideas are correct. As the famous American astronomer Maria Mitchell (1818-1889) put it, “Question everything”. The result is that theories come and go, or at least are modified through time, as old ideas are questioned and new evidence is discovered.

Science and Knowledge

Science does not give statements of absolute eternal truth - it only provides theories. We know that those theories will probably be refined in the future, and some of them may even be discarded in favour of theorist that makes more sense in light of data generated by future scientists. However, our present theories are our best available explanations of the world.

This leaves people with a choice today. One option is to accept, perhaps with some scepticism, the scientific (and only theoretical) understanding of the natural world, which is derived from all the observations and measurements described above. The other option is to accept traditional understandings of the natural world developed centuries or even millennia ago by people who, regardless how wise or well-meaning, had only sharp eyes and fertile imaginations as their best tools.

Historical Background

The history of science education takes us back to ages of Stone. During the Neolithic Age, stones were used as the primary tool material for different tools and weapons. Evolution of agriculture and cultivation also took place in this era and fire was used for the first time in history for the fulfilment of human needs. And also artificial resources for fire enlightenment were discovered. This was the time when “discoveries” started to be done by humans.

Globalization

Globalization has made economic life more competitive and demanding, making human expertise development more

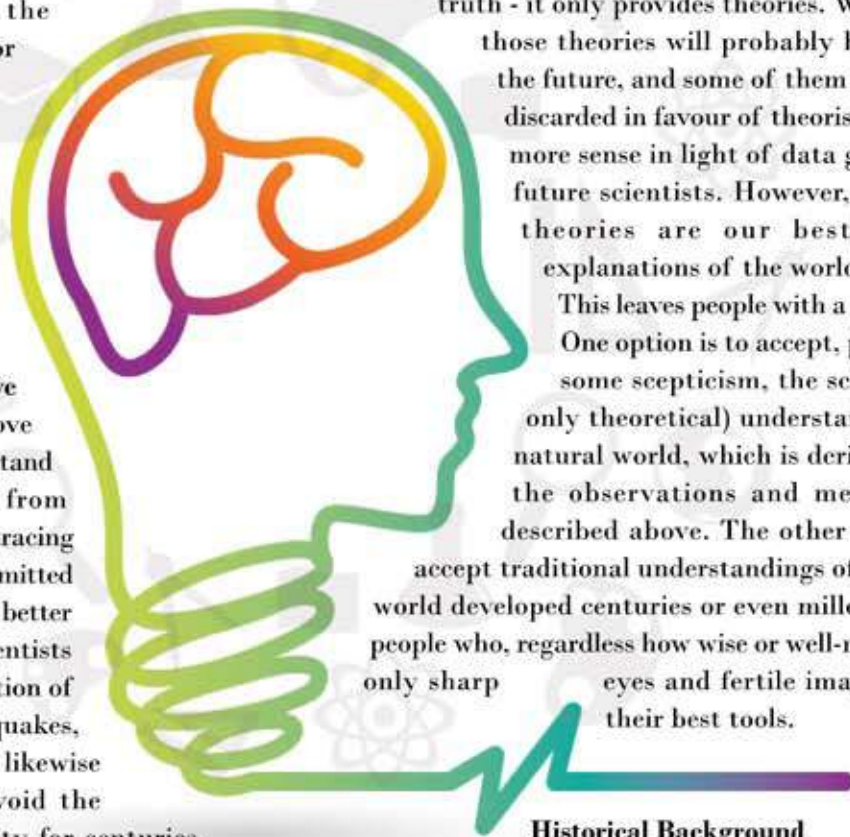

Every Japanese mother regard education of her children her prime duty. It is said that a Chinese mother travelled long distances to take evening classes for years on behalf of her disabled son and then taught the boy with her notes taken in the class.



significant. Only an educated workforce equipped with modern skills can compete and benefit from exploiting the opportunities created by globalization.

Numerous empirical studies conducted by social scientists have established a strong correlation between education and national development. The Jomtien Conference 1990, the report of the Jacques Delors Commission on Education for the Twenty-first Century, and the United Nation's Millennium Development Goals (MDGs) all are utmost importance to education as an effective tool in reducing poverty by building a viable workforce capable of competing in an increasingly competitive and global economy. It is an acknowledged fact that universal literacy played a significant role in the phenomenal advancement of the United States and other western countries in almost every field of life.

Similarly, countries like Japan, Korea, Singapore, Malaysia and Thailand had achieved near universal literacy before joining the coveted club of developed nations.

Three factors are mainly responsible for converging the world: first, the introduction of scientific and technological innovations in the field of communication has removed all the boundaries. Information technology has already taken the world by storm and would continue to affect all aspects of human life. Molecular Biology and Genetic Engineering are revolutionizing science. The second factor is the dismantling of the Eastern Bloc and the emergence of new regional economic blocs like the ASEAN, the EU and SAARC. The third is the dominance of an ideology of market-led regulation, initially applied to economic and financial exchanges, and now applied to a variety of other

sectors of human activities including health and education. Today, most of the developing countries are suffering from a host of economic and socio-political maladies such as unemployment, low earnings, inflation, corruption, rapid population growth and political instability. In majority of the SAARC countries, the significance of education a tested and proven means of nation building has never been fully realised by the masses and the policy-makers alike. A number of education policies and innovative programmes launched to promote literacy in these countries have failed to yield the desired results mainly due to lack of dedication and efficient implementing machinery.

In the present era of competition, survival has increasingly become daunting. Only those nations and individuals can successfully meet the challenges of globalization who have vision and can translate it into action. Studies have shown

According to latest estimates, average literacy rate of South Asia is 43 percent, well below the world average of 60 percent. Education systems have failed to bring about the desirable transformation either in the prevalent social milieu or in the behaviour and outlook of individuals.

that such competence and skills are more readily acquired if students get an opportunity to try out and develop their abilities by becoming involved in practical work.

Every Japanese mother regard education of her children her prime duty. It is said that a Chinese mother travelled long distances to take evening classes for years on behalf of her a disabled son and then taught the boy with her notes

taken in the class. All these instances illustrate the high value attached to education in Asia.

Many East Asian countries have been heavily influenced by the Japanese model of education. Beginning with the Meiji era, primary education was made compulsory for all in Japan by 1870. After establishing primary education for all, secondary education for all became the goal, and after the Second World War tertiary education received the focus. The Japanese were probably the first to realize that it was essential for their very survival as a nation to appropriate for them-selves, Western learning, like mathematics, science and technology.

In the nineteenth century, majority of the South Asian countries did not make conscious efforts to educate their people on modern lines. The introduction of Western education particularly in the sub-continent was resented on grounds that the educated elite was more steeped in Christian theology, history, literature and culture than in science and technology.

However, South Asian countries as a whole failed to develop their own system to protect their culture and values, and to compete globally. According to latest estimates, average literacy rate of South Asia is 43 percent, well below the world average of 60 percent. Education systems have failed to bring about the desirable transformation either in the prevalent social milieu or in the behaviour and outlook of individuals. Thus the region cannot attain its regional objectives by producing people who are capable of only reading and writing. The current educational system is producing people with skills that are not directly relevant to the needs of present day society. It would not be too wrong to say that SAARC countries are lagging far behind in education and the present situation cannot be allowed to persist.

The emerging picture suggests that there are ongoing demands on the educational system to explore meaningful ways to improve and widen access to learning and provide opportunities to a larger segment of the societies in the South Asia.

Science Education and Economy

Economic development is a goal of all nation-states, and a

life necessity for lesser developed countries. Strategies for economic development stress the importance of science and technology in accomplishing such goals.

It has been argued that high rates of education are essential for countries to be able to achieve high levels of economic growth. Empirical analyses tend to support the theoretical prediction that poor countries should grow faster than rich countries because they can adopt cutting edge technologies already tried and tested by rich countries. However, technology transfer requires knowledgeable managers and engineers who are able to operate new machines or production practices borrowed from the leader in order to close the gap through imitation. Therefore, a country's ability to learn from the leader is a function of its stock of "human capital." Recent study of the determinants of aggregate economic growth have stressed the importance of fundamental economic institutions and the role of cognitive skills.

What is Economy?

An economy consists of the economic system of a country or other area, the labour, capital and land resources, and the economic agents that socially participate in the production, exchange, distribution, and consumption of goods and services of that area.

Relation between Economy and Science Education

The science of socio-economic development there are four pillars, knowledge, technology, innovation and the most important of all, an honest visionary and competent



leadership that recognises the need for investing in human capital, building institutions for, adoption and creation of knowledge, its commercialisation and diffusion for productivity gains, employment creation and poverty reduction in the opinion of Dr. Ata-ur-Rehman. In an article, he elaborated that the first pillar of knowledge can be subdivided into four critical sub-components that must all come together to make a coherent whole. They are compulsory primary education for all, and high quality secondary, technical and university education compatible

which is to be produced by the high quality technology colleges having internationally reorganisation degree and diplomas. Pakistan government must concentrate to

Technology can be thought of as process, as knowledge and as artefact (products, tools, and instruments). Designing demands that we plan change so that we end up with desired results, minimize trade-offs, and control risk.



with the best international standards. He said that to make this happen, the emphasis must be on attracting the brightest and highly qualified professionals into the teaching profession. Giving comparison, he said that the Malaysian government is spending 25% of its budget for the last 30 years on education and as a result its exports are US \$155 billion annually as compared to US\$19 billion from Pakistan. The second pillar is technology. Most developed countries prepare their technology-based development vision for concentrating resources in a few niche areas. Finland, with a small population, identified telecommunications and agro-forestry through such an exercise about 20 years ago. Today, just one leading cell phone manufacturer from this country has exports of about US\$40 billion; more than double the total exports of Pakistan.

Pakistan government had conducted a similar exercise as a result of cabinet decision in year 2003. The cabinet approved on August, 2007 the technology-based industrial vision and strategy for Pakistan's socio-economic development but the same was largely un-implemented. If implemented, this would certainly help to identify the technology, policy skills gaps for addressing key issues confronting our industry. We must strengthen our colleges and universities as well to provide the needed research inputs for new technology development. Our industry needs a qualified workforce

implement metrology; standards, testing and quality in order to produce world quality products for enhance its exports.

The third pillar is innovation, which requires the systemic flow of knowledge between the products and users of knowledge. It is urgently needed to develop the absorptive capacity of our industrial concerns which enable them to innovate- their learning ability, prior accumulated knowledge and organisational capabilities. This could be possible that government will encourage the industrial concerns through appropriate measures that additional employment opportunities will be created.

Coming to the fourth and the most important pillar is that of an honest, educated, enlightened and competent leadership that can ensure strict adherence to merit, supremacy of law and its quick dispensation and that understands what it takes to transition to a knowledge economy. In china many cabinet members are eminent scientists and engineers.

Impacts on Human Resources, Technology, Industrialization & Environment

One of the major challenges facing human resources planning is dealing with the uneven level of technological development in different countries. The world has witnessed a huge scientific and technological explosion in recent decades; but not all societies have been equally affected by this process. Yet the ability to master and apply science and technology are indispensable to the process of modernization and development of economies. More recently, science education seems to have particularly suffered from the economic austerity which has led to a decrease in real terms of the resources allocated to education in a number of countries. All these problems have been aggravated by lack of co-ordination between the numerous administrations and institutions concerned with secondary education and by insufficient planning. As a result, science education in a large number of countries is still in a critical state. Technology can be thought of as process, as knowledge and as artefact (products, tools, and instruments). Designing



demands that we plan change so that we end up with desired results, minimize trade-offs, and control risk. Technologists, such as engineers, industrial designers, and architects, use the process to find solutions to technological problems.

By studying science and technology, students gain a unique perspective on these important forms of human thinking and doing. Science seeks answers to questions about the natural universe and answers the question "Why?" Technology, in attempting to adapt our environment, seeks answers to questions about the designed world and answers the question "How?" Advances in scientific knowledge often support new technological inventions as the human need to learn more about the natural universe presents new problems for technological development.

What the scientists and national leaders alike failed to understand was that development does not necessarily coincide with the possession of nuclear weapons or the capability to launch satellites. Rather, it requires modern agriculture, industrial systems, and education. The technical elite naïvely believed that spin-offs from their nuclear energy or space programs would somehow convert their countries to 20th-century industrialized states.



As time progresses, countries seem to be able to grow at a much more rapid rate. From 1780, it took Great Britain 58 years to double its real income. It took America 47 years to double in the 1800's while Japan took 34 years from the late 19th century.

This scenario means that we in developing countries should not expect to follow the research model that led to the scientific enterprise of the United States and elsewhere. Rather, we need to adapt and develop technologies appropriate to our local circumstances, help strengthen education, and expand our roles as advisers in both government and industry. In this way, we can prevent the brain-drain of our scientists, engineers and doctors.

Economic Profile of East Asian Countries

Over the past decade, there has been rapid long-term economic growth for East Asian countries. These newly industrialising countries are experiencing growth rates in GDP per head at around 6% to 7% compared to the 2% to 3% for most industrial economies. If this growth continues, South Korea and Taiwan might take away America's distinction as the world's richest country. This economic growth is a result of economic and political factors. The pace of economic development, growth in world trade and communications, and investment in physical capital and education have played a role in the rise of the East Asian economies.

As time progresses, countries seem to be able to grow at a much more rapid rate. From 1780, it took Great Britain 58 years to double its real income. It took America 47 years to double in the 1800's while

Japan took 34 years from the late 19th century. Finally, South Korea was able to double its real income in an amazing 11 years from 1966.

East Asia is investing much of its GDP in physical capital and education. Compared to the industrial leaders, the East Asian countries have sustained a much higher investment in these areas. South Korea invests 35% of its GDP which is more than double America's capital spending.

The standards of education for these countries have improved as rapidly as their economies. No longer is a country's economy hurt by a small domestic market. World trade has grown tremendously over the past few decades. Exports account for about 30% of South Korea's GDP and 40% of Taiwan's.

South Korea and Taiwan should continue to experience long-term economic growth in the next several years. Both countries are investing heavily in education and physical capital; areas which are key for economic development. They also are benefiting from world trade and the diffusion of new technologies.

Country or territory	GDP nominal millions of USD (2009)	GDP nominal per capita USD (2009)	GDP PPP millions of USD (2009)	GDP PPP per capita USD (2009)
China	4,908,982	3,678	8,765,240	6,567
Hong Kong	210,731	29,825	307,065	42,748
Japan	5,068,059	39,731	4,159,432	32,608
Macau	21,700	40,185	18,140	59,451
Mongolia	4,023	1,560	9,399	3,481
N. Korea	27,820	1,159	40,000	1,800
S. Korea	832,512	17,074	1,364,148	27,978
Taiwan	378,969	16,391	735,997	31,834

ECONOMIC PROFILE OF PAKISTAN

The economy of Pakistan is the 27th largest economy in the world in terms of purchasing power, and the 48th largest in absolute dollar terms. Pakistan has a semi-industrialized economy, which mainly encompasses textiles, chemicals, food processing, agriculture and other industries. Growth poles of Pakistan's economy are situated along the Indus River, diversified economies of Karachi and Punjab's urban centres; coexist with lesser developed areas in other parts of the country.



Background

Historically, Pakistan's overall economic output (GDP) has grown every year since a 1951 recession. Despite this record of sustained growth, Pakistan's economy had, until a few years ago, been characterized as unstable and highly vulnerable to external and internal shocks. However, the economy proved to be unexpectedly resilient in the face of multiple adverse events concentrated into a four-year (1998-2002) period.

The Economy Today

Due to inflation and economic crisis worldwide, Pakistan's economy reached a state of Balance of Payment crisis. "The IMF bailed out Pakistan in November 2008 and in July last year increased the loan to \$11.3 billion from an initial \$7.6 billion. By October 2007, Pakistan raised back its Foreign Reserves to a handsome \$16.4 billion. Exceptional policies kept Pakistan's trade deficit controlled at \$13 billion, exports boomed to \$18 billion, revenue generation increased to become \$13 billion and attracted foreign investment of \$8.4 billion.

From 2008, Pakistan's economic outlook has taken stagnation. Security concerns stemming from the nation's role in the War on Terror have created great instability and led to a decline in FDI from a height of approximately \$8 bn to \$3.5bn for the current fiscal year. Combined with high global commodity prices, the dual impact has shocked Pakistan's economy, with gaping trade deficits, high inflation and a crash in the value of the Rupee, which has fallen from 60-1 USD to over 80-1 USD in a few months. For the first time in years, it may have to seek external funding as Balance of Payments support.

The middle term however may be less turbulent, depending on the political environment. The EIU estimates that inflation should drop back to single digits in 2010, and that growth should pick up to over 5% per annum by 2011. Although less than the previous 5 years average of 7%, it would represent an overcoming of the present crisis wherein growth is a mere 3.5-4%.

Education in Pakistan

"There is no doubt that the future of our State will and must greatly depend on the type of education we give to our children and the way in which we bring them up as future citizens of Pakistan".



“There is no doubt that the future of our State will and must greatly depend on the type of education we give to our children and the way in which we bring them up as future citizens of Pakistan”

Council for Science and Technology is the designated secretariat of NCST and in this capacity; it plays a very important role in the policy formulation and decision-making process. Chairman, PCST, supported by a small technical workforce,

Science and Technology Governance in Pakistan

Pakistan inherited four laboratories, one university and one agricultural college in 1947. Since inception, Pakistan realized the importance of science and technology for socio-economic development, however, due to various reasons, mainly financial constraints and political instability, science and technology couldn't become the priority agenda of successive governments.

Despite these constraints, considerable progress has been made. At present; there are 83 major S&T organizations with over 224 laboratories and research stations in Pakistan. In addition, there are 109 universities, about half of which are in the private sector.

For making the role of parliament in the development of science and technology more efficient and well-organized, various mechanisms have been devised in Pakistan. In this regard, the National Commission for Science and Technology (NCST) is the most important institution which was created in 1984. The 27-member Commission is the apex Science and Technology policy laying body that provides guidance for scientific and technological efforts in the country. It has a cross-cutting function of determining policy across many government ministries and agencies and, it does not have any administrative function. The Commission is headed by the Prime Minister of Pakistan and includes Federal Ministers for Science and Technology, Education, Agriculture, Industries and Finance along with Ministers for S&T Departments of the provinces.

The Commission has an Executive Committee that is responsible to coordinate, oversee and review the policies, research and development programmes and implementation of the decisions taken by the Commission. The Executive Committee is headed by the Federal Minister for Science and Technology and consists of 29 members.

serves as the Secretary of the Commission. National Assembly and Senate have Standing Committees on Education, Science & Technology. Presence of these Committees provides political oversight over the functioning of these organizations in the country. Recently, a Sub-Committee of the Senate Standing Committee on Science & Technology considered the linkages between industries and research institutes.

Ministry of Science and Technology is focal point on all important matters regarding science and technology including developing policies and plans and, coordination of science and technology at the government level. Keeping in view the importance of IT and acknowledging its central role in the future economic progress, a separate ministry was created for IT and Telecommunications. Other important federal ministries with regard to science and technology are ministries of Education, Agriculture and Industries. Higher Education Commission (HEC) and Pakistan Atomic Energy Commission (PAEC) are other important bodies where decisions, pertaining to their spheres of work, are made. Both the organizations are also represented on the NCST through their heads. Chairman, HEC, who has recently been posted as Advisor to the Prime Minister, is responsible for higher education, including education, research & development in basic and applied sciences and engineering & technology.

There are a significant number of Research & Development organizations, mainly in the area of agriculture, working under the administrative control of the provinces. While heads of science and technology organizations working under the administrative control of different federal ministries, mainly science and technology and, agriculture, are responsible for governance of these organizations at the local level.

Literacy Issues

The education system after 57 years of independence lacks cohesion and even proper distribution. The education



indicators in Pakistan have been persistently poor: High illiteracy rate, especially of females, the participation rate at primary level is around 73% and at secondary level around 24%. Completion/survival rate to grade 5 is 72%. The overall literacy rate of 53% (65% for males and 40% for females in 2004) demands proper attention towards the problem of low literacy. Net primary enrolment ratio was 46% in 1990-91 and is expected to reach 58% by 2005-06. The literacy rate and net primary enrolment are low not only as absolutes but also in comparison with other countries in the same development bracket.

Low female literacy rate is one of the main causes of women's low participation in the political, economic and social

target of providing free and compulsory primary education within a decade. This was followed by the appointment of various commissions beginning with the Report of the Commission on National Education (1959). The Education Policy of 1972 nationalized the private educational institutions. In broad terms, each policy invariably emphasized the following:

Universal primary education and promotion of literacy
Progress towards science and technology
Quantitative improvement of education
Reduction in inequalities of educational access and opportunities
Availability of technical and professional education.

The education system after 57 years of independence lacks cohesion and even proper distribution. The education indicators in Pakistan have been persistently poor: High illiteracy rate, especially of females, the participation rate at primary level is around 73% and at secondary level around 24%. Completion/survival rate to grade 5 is 72%.



activities. They cannot achieve their rights and compete for available opportunities in the job market. This situation has led to the social and economic dependence of women which in turn ensures male domination in society. Under globalization women have been perceived as victims of economic globalization and structural adjustment programmes (Sassen, 1998). It is feared that globalization process is likely to affect gender relations and will be detrimental to women (Arizpe, 1997; Beneria, 2003).

Since independence, various governments have acknowledged the importance of education and adopted policies to make education accessible to all. An All Pakistan Education Conference was held in 1947, which laid down an ambitious

Easy access to higher education on merit
Access to employment opportunities through education and training
The 1979 Education Policy denationalized some of the nationalized educational institutions, but majority of them continued to operate under public sector management. The private sector was, however, encouraged to establish new institutions.

A Literacy and Mass Education Commission (LAMEC) was established in 1981 to evolve strategies and plans for formal and non-formal mass education to enhance literacy. The concept of mosque and 'mohallah' schools was introduced.

The National Education Policy 1992 - 2002 recognized the



fundamental right of every Pakistani child to get education. It was made compulsory and free to achieve universal enrolment by the end of the decade. The National Education Policy 1998-2010 was formulated to consolidate the earlier efforts with renewed commitment. The policy sought to increase literacy by launching the National Literacy Movement. On the formal side, the policy envisaged the integration of primary and middle levels into elementary education. It also emphasized improvement in access and quality of elementary education by optimal utilization of existing facilities. The policy highlighted the importance of management, monitoring and supervision at all levels, particularly with a view to decentralizing decision making.

All the Five Year Development Plans and recently Education Sector Reform Plan and Mid-Term Development Framework (2005-11) have recommended that:

Developments in agriculture and industry and heavy investment at the primary level to reveal talent and to lay the basis of attitudes of mind essential to development. This will improve the secondary and higher stages of education, which have been recruiting from too narrow a base in the past. In addition, it will eventually furnish the necessary expanded inflow into technical and vocational institutions and would lead to a knowledge society.

A lesson for Pakistan

The modern economic is driven by science and technology that provides the productivity and economic growth in all areas like renewable energy, agriculture, manufacturing, transportation, communication engineering, finance, banking and other services. The scientific knowledge is the key element in a national security dimension and in recent wars the technology has played the crucial role.

The hypothesis of this report revealed that the education plays a key role for understanding various aspects of the socio-economic challenges whereas the science education provides a way to enhance the capacity building of available human resource and its practices, how the technology could provide the mechanism to produce more in quality as well as in quantitative terms.

The East-Asian countries investment in HR developing is remarkable. Malaysia alone has provided 25% of its resources for education sector from the last 10 years. Similarly, South Korea and China are the most relevant example, how the economic growth could take off through science education. The higher education commission (HEC) has already set the platform for the scientific knowledge based education



system
in the
country but no
benefit has been availed

by either the public or the private sector. The country is mostly dependent upon the imported items almost in all walks of life. Pakistan is not benefiting from their available human resources, like the scientist, the research based institutions and several science departments already exist in various universities of the country.

It is known fact that the science education in the country considered as a problematic area, for understanding these phenomena, a nationwide survey was carried out in year 2003 on the following terms of reference:

1. A test of students in core science subjects.
2. A survey of teacher's qualification.
3. An analysis of officially prescribed text books.
4. An appraisal of the pattern of examination & question papers.
5. An assessment of laboratory manuals and practices.
6. A review of library lending records.
7. School visitors, interview with school & college principal, science teachers, laboratory supervising staff and students.

It is revealed from this survey that the science education from middle to higher secondary school level is basically a routine method of examination, on the pattern the curriculum and the qualifications of teachers have nothing long but this demands strong revolutionary changes in the present pattern. However, after the establishment of higher education commission in the year 2002, a considerable work on research have been carries out but no in-depth study has been done to utilize the science education as a mechanism for technology based industrialization. The East Asian country as per there strategy has adopted science education as a tool of economic development. Their GDP and per capita income has been increased tremendously, taking example of South Korea, who had with the help of technology produced millions of mobile telephone on a very cheaper price. As per economic term the economy of the scale reduces the price of any commodity. The South Korea does not have the raw material as well as the cheap labour in comparison to Pakistan we have abundant raw material as well as the skilled labour force which could if be utilized effectively through the right application of the technology in our industries as being done by these East Asian countries this would bring a economic revolution in the country since Pakistan is full of resources both on ground and underground which are explain as under:

The Chine's economy compared with Pakistan, in 60's it was just one third of experts in comparison to Pakistan. In fact 60's era Pakistan export was US \$6 billion whereas China's was at US\$ 2 billion. In 70's Chine's exports was US\$18 billion whereas Pakistan was at US\$6 billion. Similarly in 80's, it was US\$50 billion whereas Pakistan stood at US \$8-9 billion. Presently we are exporting US \$17 billion and China has crossed over US \$1000 billion. This was the vision of their honest leadership which prosper the people of China and economy around the world.

In 80's era, it was the vision of the world that in few years, Pakistan would be the Asian trigger but it is unfortunate that the inconsistent policy of the Government, the Japan, who wishes to invest in Pakistan, but considered Thailand



The country is exporting rice and wheat for the last many years except for the last 3-4 years when wheat is not exported due to acute shortage

and Malaysia for their business partners due to consistence policies. The Korean's economy has been developed so rapidly that was due to science education, introduction of new technology, especially in the field of telecom industry alone. This has been done by the dynamic leadership of our famous economist Dr. Mahboob-ul-Haq who gave the vision back in 70's. The East-Asian countries are benefitting with our models and technocrats but we are totally ignorant. Another example of establishing human resource development in Malaysia, in early 80's the Malaysian Government asked the Pakistan Government to help them in this sector. The Pakistani provided the blue print of their human resource training institutions which was subsequently replicated in Malaysia and formed the institute with the name of National Institution of Public Administration (INTAN).

The other fertile area which has not yet been touched upon by the Government is plantation of palm oil trees on our long belt of coastal area. This would have given an edge to Pakistan for boasting its economy on the pattern of the Malaysian model by simply replicating it with the help of Malaysian government. Malaysia have a 250 km coastal area through which the honest and visionary leadership of Malaysia converted it into an economic opportunity by effective usage of technology hence they were able to stabilize their economy. The improved economic indicators by exporting Palm oil to various countries of the world including Pakistan are witnessed. On the other hand Pakistan is unable to explore such venture which could have helped them for



stream lining its socio-economic conditions. This single alone sector would have provided Pakistan an opportunity to increase its GDP and per capita income since Pakistan is having a costal line spread over 1200 km. The export of palm oil would have helped the Pakistan to increase per capita income/GDP & enable to stream line its balance of payment. The cultivation of tea would be another area as a huge chunk of foreign is used for import of tea from Sri Lanka. This will also reduce the burden upon our foreign reserves.

The Sindh coal reserves which are more than the oil reserve of Saudi Arabia and Iran would have been another area of our economic development. This needs latest technology to utilize the available resources more economically without unnecessary wastages.

Agro Based Economy

The Pakistan solely depends upon its agricultural based production. The country is exporting rice and wheat for the last many years except for the last 3-4 years when wheat is not exported due to acute shortage. Beside this few fruits are also being exported like mango & kinu. Pakistan has a great potential in export of livestock and dairy products because, Pakistan is amongst the four countries which are key producers of dairy and dairy based products beside livestock. This export could have given a fair chance to boast Pakistan's exports and reduce its debt servicing. Borrowing loan from IMF is not the solution of the problem. The Country,s leadership must find out some other means so that the country will rely upon more taxation or to find

other means of funds generation strategy in such a way to meet out its budgetary requirement. This will also provide sufficient spacing to the country to control circular debt.

The lesson Pakistan could have to learn from the East-Asian countries, to enhance investment up to 25% in education sector which will resultantly provide windows for creating more skillful human resource, better understanding of technology, transfer of technology and innovation. The most important factor would be the creation of honest leadership which provides merit based decision making system.

God has gifted Pakistan with all available resources but it is much needed to explore these opportunities and convert it in to a meaningful way so that to maximize the economy. The skilled and unskilled human resource is available in Pakistan but we need to replicate various models to improve our economic growth as being done by East Asian countries. The effective utilization of technology will convert in to economic opportunities but that needs constant understanding of learning science education both at the secondary level, vocational training institution as well as higher education level.

We have already wasted considerable time and money but it is a general belief that if there is a will, always there is a way. To overcome the issue of economic growth, enhancement of GDP ratio and per capita income it is urgently needed to prioritize our area of responsibilities in order to boost the economy of the country and make Pakistan as Asian tiger as being visualized by the develop world in early 80's.



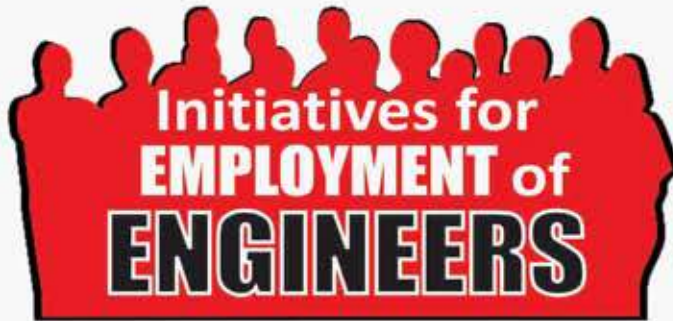

JobShop

- PEC JobShop web interface (<http://www.pec.org.pk/jobshop.aspx>) provides profile of unemployed engineers and jobs posted by national and overseas employers.
- Purpose is to connect the unemployed engineers with the potential employers.



PEC E-Group

- An online group (<http://www.pec.org.pk/pr>) where engineers share valuable information, relevant jobs, training opportunities, scholarships and business ventures.



Employment in Construction and Allied Industry

- PEC has made mandatory to employ engineers for performance of engineering works in construction firms and allied industry necessary.
- Registration and renewal of a construction / allied firm from lowest category (C-5) to No Limit firm is only subject to employment of relevant engineers.
- This initiative has provided job to around 30,000 engineers in Pakistan.
- Even fresh graduates get the job



Privilege to start Construction / Consulting Firm

- PEC encourages the unemployed Engineers and Non-engineers a new business as a construction or operator or service provider firm.
- PEC also offers to set up a consulting firm in any field for engineers with 10-years experience or with master degree engineering degree.
- Allied professionals may also become partner with engineers

For details visit: www.pec.org.pk

**Call at our Helpline:
051-111-111-732**

**Phone: (+92-51) 2829348,
2829311, 9206974**

Fax: (+92-51) 2276224

Email: info@pec.org.pk

**Pakistan Engineering Council,
Attaturk Avenue (East) G-5/2,
Islamabad
[facebook.com/pecofficial](https://www.facebook.com/pecofficial)**



3G & 4G

in the World of TELECOMMUNICATION

Before starting something about the 3G & 4G, I would like to explain in brief about the era of 1G and 2G.

Brief Introduction of 1G & 2G

1G stands for the first-generation of wireless telephone technology or the first generation of later on acquiring popular buzzing synonym of wireless telephony i.e. "The Mobile Cellular Phone". That was the telecommunication's standard regime based on analogue technology and was introduced in 1980s and remained enforced until gradually replaced by its 2G digital successor telecommunication networks. The core difference between these two succeeding mobile telephone systems was of air interface and its transmission systems, more explicitly, 1G networks used to air signals using analog transmission, whereas 2G networks utilized digitally modulated signals to air signals. Although voice is coded digitally in both generation systems as source signal, however 1G systems it was transmitted after modulating on higher frequency in purely analogue signal formats (analogue domain), the reference modulated frequency beginning from 150 MHz. and onwards. Due to this milestone advantage it overwhelmed its predecessor instantly, everywhere in the world.

By: Engr. Abdul Rehman Shaikh
Senior Manager PTCL
Member P.R. Committee
(Sindh)



3G telecommunication networks support services that provide an information transfer rate of at least 200 Kbit/s.



One of the examples of 1G standard is classical NMT (Nordic Mobile Telephone), used in Nordic countries (Switzerland, Netherlands, Eastern Europe and Russia). Others include AMPS (Advanced Mobile Phone System) used in the North America and Australia, TACS (Total Access Communications System) in the United Kingdom, C-450 in West Germany, Portugal and South Africa, Radiocom 2000 in France, and RTMI in Italy.

The speed of 1G varies from 28kbit/s to 56kbit/s.

Brief History

1G was an analogue system, and was developed in 1970's. 1G devices had incorporated two major improvements of the state of the art technology, i.e. the invention of the microprocessor, and the digital transform of the control link between the phone and the cell site.



Moreover, 1G analogue system for mobile communications saw two key improvements during the 1970s: the improvements in the microprocessor systems and the digitization of the control link between the mobile phone and the cell site. Advance Mobile Phone System (AMPS) was first launched by the US and is a 1G mobile system. Based on FDMA, it allows users to make voice calls in 1 country.

2G Generation Wireless Telephone Technology:

Second generation, 2G cellular telecom

networks were first launched commercially on the GSM platform in Finland by Radiolinja (now part of Elisa Oyj) in 1991. Three primary benefits of 2G networks over their predecessors were that phone conversations were:

(a) digitally encrypted; 2G systems were significantly more efficient on the spectrum allowing for far greater mobile phone penetration levels;

(b) 2G introduced data services for mobile, starting with SMS text messages. 2G technologies enabled the various mobile phone networks to provide the services such as text messages, picture messages and MMS (Multi Media Messages). In addition to that, text messages sent over 2G are digitally encrypted, allowing for the transfer of data in a secure way that only the intended receiver can receive and read it.

After 2G was launched, the previous mobile telephone systems were retrospectively dubbed 1G. While radio signals on 1G networks are analogue radio signals on 2G networks are digital. Both systems use digital signaling to connect the radio towers (which listen to the handsets) to the rest of the telephone system.

3G Wireless Telephone Technology:

3G stands for 3rd Generation of mobile telecommunications technology and also known as tri-band 3G. This is based on a set of standards used for mobile devices and mobile telecommunication use services and networks that comply with the International Mobile Telecommunications-2000 (IMT-2000).

3G finds application in wireless voice telephony, mobile Internet access, fixed wireless Internet access, video calls and mobile TV.

3G telecommunication networks support services that provide an information transfer rate of at least 200 Kbit/s.

History of 3G & 4G:

3G technology is the result of research and development work carried out by the International Telecommunication Union (ITU) in the early 1980s. 3G specifications and standards were developed in fifteen years. The technical specifications were made available to the public under the name IMT-2000. The communication spectrum between 400 MHz to 3 GHz was allocated for 3G. Both, Public and private sector operators approved the 3G standard. The first pre-commercial 3G network was launched by NTT DoCoMo in Japan in 1998, branded as FOMA. It



was first available in May 2001 as a pre-released (in testing phaset) of W-CDMA technology. The first commercial launch of 3G was also by NTT DoCoMo in Japan on 1 October 2001, although it was initially somewhat limited in scope, broader availability of the system was delayed by apparent concerns over its reliability.

4G Wireless Telephone Technology:

4G is short for 4th Generation Wireless Technology; 4G is the latest in all wireless telephone technologies because of its high speed improved and new features. 4G provides the data transfer speed equivalent to the lightening speed that is amazing, provides the services such as mobile web access, IP telephony, Games, HD movies, Video Calls and conference calls, Multimedia newspapers, 3D TV and Cloud Computing. Thus unfolding the new IT revolution.



The first pre-commercial 3G network was launched by NTT DoCoMo in Japan in 1998, branded as FOMA.

For feedback & comments

sheikhmukhtar@hotmail.com, engrhab@gmail.com
makhan613@gmail.com, pr@pec.org.pk

AN OVERVIEW OF **DIGITAL SATELLITE NEWS GATHERING**

AND IT'S DIFFERENT ASPECTS IN PAKISTANI NEWS INDUSTRY

by: Engr. Bilal Ahmed

ABSTRACTS.

Everybody has natural instinct to know what's happening around .Real time access to information is matter of public importance in any society and News channels play important role in delivering live news of different day to day events from very remote areas to congested cities. And Digital Satellite News Gathering DSNG does this job by establishing link between center studios and remote location through Very Small aperture terminal system. Easy and Uninterrupted coverage are the main reasons it is considered the back bone of News industry around the globe. This paper focuses on study of Digital Satellite News Gathering system, its working principals, equipment, different aspects connected to Pakistani News industry.



INTRODUCTION.

Satellite communications represents the commercialization of space. It is aimed at achieving ever increasing communication ranges and capacities at the lowest possible costs for its customers. Different economies are greatly investing in this industry to serve different purposes of their interests [1]. A communication satellite is a spacecraft that orbits the earth and relay messages, through radio, telephone and television signals. A number of three geosynchronous satellites can cover the whole world thus making communication between individual at two remote locations in the world easier. Stations on the ground, called earth stations, transmit signals to the satellite, which then relays the signal to other earth stations. Communications between people that used to take days or even months, now take only minutes or seconds using satellites. Satellites can be grouped based on their locations in the spacecraft as the GEO, MEO and LEO. Geostationary Earth Orbit (GEO), also known as geosynchronous satellite, is located at an altitude of 22,300 Miles above the earth, the Low Earth orbit (LEO) is located a few 100 miles above the earth and the MEO known as the Medium Earth Orbit lies at a position in between the two. The satellite communication also consists of earth station from where signals are received and transmitted to. In practice, there is always a large Earth station referred to as hub. This hub is usually very expensive and more difficult to maintain. From this hub, several smaller terminals can then be connected to, which serves as intermediary between the smaller terminals and the satellite. These smaller terminals are termed the VSAT (Very Small Aperture Terminal). VSAT is a form of small earth station which can transmit, receive signal to the satellite via the internet. [2] And Television industry greatly relies on Satellite communication. Digital Satellite News Gathering System is the masterpiece that makes live operations possible for news coverage. Natural calamities, sports, political activates, infotainment and entertainment and many other segments like on-line banking, e-commerce, e-village, and health etc. are also possible due to this technology, considering that commercial TV is the largest segment of the entertainment industry, these developments brought about an attendant economic growth.



Satellites are used to carry network signals from central studios to multiple receive earth stations, each connected to a local TV transmitter. When equipped with forward-link equipment, the remote Earth Station can transmit a signal back to the central studio allow the station originate programming for the entire network. This reverse point-to-point feature can be used for enhanced services such as on-location news reports. Revenue for local broadcast operations is available from monthly subscription by TV watchers. The interior of a typical DSNG looks like a small control rooms mounted on vehicle. As technology evolves the bulky systems are converting to smart systems with reduced sizes and costs having single computer using multiple monitors or screens. An editing suite, which used to weigh many kilograms, can now be replaced by a smart computer. This is made possible by the fact that digital video is easier to transport, because its takes less bandwidth compared to analogue. As many news channels operate in Pakistan and each maintains a fleet of DSNG's all over the country. These DSNG vans approach each location where there is news and provide live coverage to viewers sitting in front of TV screens.

WHAT IS DSNG SYSTEM?

DSNG stands for digital satellite news gathering. DSNG is vehicle mounted satellite communication equipment that is used to communicate with other earth stations via satellite. [fig 1]. A communication satellite functions as an overhead wireless repeater station that provides a microwave communication link between two geographically remote sites. Due to its high altitude, satellite transmissions can cover a wide area over the surface of the earth. Each satellite is equipped with various "transponders" consisting of a transceiver and an antenna tuned to a certain part of the allocated spectrum. The incoming signal is amplified and then re-broadcast on a different frequency. Most satellites simply broadcast whatever they receive, and are often



Fig1: Block Diagram of DSNG Network.

The frequency and cost has directly relationship. If we use low frequency equipment will be cheap but bigger in size.

referred to as "bent pipes". These were traditionally used to support applications such as TV broadcasts and voice telephony. DSNG is mobile earth station which is used to make link

between central hub and remote locations. Each DSNG connects to any satellite having footprint in that region and communicates to local TV earth station and other DSNG's using star mesh topology.

Normally GEO satellites 36000km above the equator provide TV services and sale spectrum of C and KU band to TV Channels. In Pakistan DSNG services are designed on KU band as it reduces the size of equipment and also cost comparatively to C band equipment as compared to European monster DSNG's which are also designed on C band.

DSNG EQUIPMENT AND ITS FUNCTIONALITY:

A typical KU band DSNG has a dish of size 1.2 m for mounted on its roof top. Dish antenna is a complete module including BUC, Feed Horn, LNB, OM Televation and azimuth motors. This set of equipment is also termed as ODU out door unit. The IDU indoor unit includes Encoder, modulator, Antenna control unit, combiner, integrated receiver and demodulator, downlink receiver monitoring LCDs, video switcher, audio mixer, UPS, generator battery bank, video cables, tool kits, Cameras etc. [fig 2]. The internal equipment of DSNG uses L band frequency (0.8-2GHz). The frequency and cost has directly relationship. If we use low frequency equipment will be cheap but bigger in size. We can manage low frequency at earth station but at satellite





pay load is a big issue so its equipment is designed at higher frequency to reduce the pay load size.

The functionality of IDU equipment is as under:

- Camera captures the audio and video of interest and gives analogue and digital outputs to DSNG via analog or SDI cable. Typical cables are RG6, RG7, with XLR for audio and BNC for video connectors. In Pakistan almost all TV channels use PD 170, PD 177, NX 5, PWD 100 cameras for news coverage.

- Video Switcher is used to switch multiple camera feed according to the need.

- Audio mixer is used to refine audio quality, level control, hiss, chattering removal and audio switching.

- Data is in L band frequency till this stage now Encoder and modulator get output of switcher and apply sophisticated algorithms on video and encode it using MPEG 2 or 4 techniques and then modulate it over a carrier frequency using QPSK, or any other modulation scheme depending upon the equipment used. And modulated signal is fed to BUC for transmission. Here frequency is increased with the addition of carrier signal to L band signal. Tandberg, Aglow, Ericson are famous brands in Pakistan.

The Outdoor unit functions are discussed as under:

- Block up converter BUC increases the power of modulated signal so that it can reach the satellite transponder 36000 km away. It is one of the most expensive equipment in DSNG. In Pakistani news industry BUCs of Ageless, Alga, Advantech etc. are frequently used.

- LNB Low Noise Block Down converter is used to receive downlink signal and convert it to L band. This device is used for dish alignment purpose. Downlinks frequency is fed in receiver and dish is tuned on specific satellite transponder.

- OMT Ortho mode transducer is a device which separates up link and downlink frequency coming and

going through feed horn.

- Elevation and azimuth motors rotate antenna in spherical plane to get desired orbital position.
- Now data comes to feed horn keeps a small pin which radiate the signal and throw it on reflector.
- Reflector collects or scatters radiation and like concave mirror. And a beam is forwarded to satellite transponder. Reflector of ADVENT, SWEDISH, ADVANTECH, and INETVU are much preferred in Pakistani environment.

Satellite transponder collects waves and repeats the same procedure and regenerates the signal and throw on the foot print. Where each heath station is pointed towards transponder can receive that signal with limitations of different parameters.

COMMON PRACTICE IN DSNG OPERATIONS.

DSNG team includes DSNG engineer, technician, cameramen and reporters, when an initial news comes the importance of news is judged by some experts on assignment desk and if news is of channels interest the DSNG team is contacted and DSNG is moved to location by DSNG Drivers who are usually much aware of entire map of cities every there streets and shortcut routes. DSNG Engineers have a thorough knowledge and training of DSNG operation, they learn by hearth the orbital positions of different satellites and without any compass they can point out directions in unknown areas. And immediately DSNG is parked on level plane surface on safe side so that it may not cause any issue to others. Then equipment is turned on and antenna control unit points towards satellite. Meanwhile technician lays cables and makes connection, cameraman captures the footages, and reporter collects the information from people who witness the issue. And after establishment of video link to network operation center of TV Channel the story goes on air as LIVE. And the entire process takes 3 to 5 minutes. Which shows DSNG technology has made real time news possible and easy? Similarly a fleet of DSNG covers different regions and leaves no story unleashed. In Pakistan DSNG response time is very less that often it reaches on spot before other institutions like police, ambulance, or fire brigade.

CHALLENGES INVOLVED WITH DSNG TEAM.

Sometimes there are crises situations, natural and man-

made calamities, disasters, law and order issues, civil wars or bomb blasts especially in Pakistani environment. And covering all above mentioned events is very important as when NEWS Media raises any issue the government and other supporting organization accelerate their efforts to solve the problem and rating competition is also a reason to rush towards such scenes. And DSNG crew is the first victim of such situations. Many people gave their lives in covering bomb blasts and terrorist attacks and other calamities. DSNG career is tough choice as every time crew is ready to face any type of situation, you need to be mentally as well physically very tough as it is cent percent field work. Some times DSNG sticks to a location for a couple of days and things get messy.

RELIABILITY OF DSNG SYSTEM.

There are many systems exit for news coverage like "TVU Back Pack" KA Band dish system, FTP but all of them are limited to internet connectivity. And in remote location KA band system can operate but it is very sensitive to bad weather. DSNG is considered ideal for news coverage. And its success rate is clear from data analyzed that only failures are observed due to any technical fault or extreme bad weather condition. Otherwise DSNG technology can be used at any time anywhere in foot print of satellite.

CONCLUSION.

DSNG systems have made real time news coverage

possible with reliability and wide coverage area and that's why these systems are Considered back bone of News channels. From analysis of Data it is evident that these systems success rate is satisfactorily very high. Whenever there is clear line of site and equipment is working well, we are sure that link will definitely be established to central earth station. And with the advent of DSNG technology Pakistani news industry is expanding with mushroom growth. New channels are in process of launching in upcoming years.

REFERENCES.

- [1] Satellite Communications: Impact on Developing Economies VOL. 2, NO. 11, October 2011 ISSN 2079-8407 Journal of Emerging Trends in Computing and Information Sciences.
- [2] Design and Simulation of a Reduced –Size VSAT Antenna with Appreciable Gain VOL. 1, NO. 9, December 2011 ISSN 2222-9833 ARPJN Journal of Systems and Software.
- [3] Impact of video compression on video quality ,volume, 10 number 4 ,2012
- [4] <https://www.gvf.org/aboutgvf/about-gvf.html>
- [5] <https://www.howstuffworks.com/digital-satellite-news-gathering.htm>





GSM AND ZIGBEE BASED

THEFT DETECTION AND

by: Engr. Shahroz Khan



MONITORING SYSTEM FOR WAPDA

INTRODUCTION:

The Global System for Mobile Communication known as GSM is a technology that dominated mobile communication industry over the past decade. GSM originated from Europe and spread into many other countries to become a popular standard for mobile communication. GSM started mainly with voice communication, offering few basic services, then data communication was introduced, but due to slow data rate, it was useful to very few applications. Research and development brought about the different evolutions of GSM, namely HSCSD (High Speed Circuit Switched Data), GPRS (General Packet Radio Service) and EDGE (Enhanced Data rate for GSM Evolution). Presently, GSM network operators provide a wide range of services, including many new services such as web surfing, MMS (Multimedia Messaging Services), and EMS (Enhanced Messaging Services). There are a lot of useful technological products developed in the world to make life much easier, products which are not used by many simply because these are not well known or not properly understood.

ZigBee, also known as IEEE 802.15.4, is a communications standard designed for low-power short-range communications between wireless devices. It is classified as a wireless personal area network (WPAN), a term that includes the Bluetooth (IEEE 802.15.3) standard as well.

The ZigBee standard has seen increasing interest from both commercial and military customers for applications such as wireless sensor networks, home automation, and industrial control. One interesting facet of the ZigBee standard is that it is designed so that devices can create a self-forming and self-healing ad hoc or mesh network. In this scenario, a central "PAN coordinator" device oversees the health of the network configuration. In recent years, sensor networks have been the subject of much research in military/battlefield applications as well. Thus, there is significant interest in using the ZigBee standard to define the communications links in ad hoc battlefield intelligence scenarios.

One feature of the ZigBee specification that makes it ideal for remote wireless sensors is the implementation of a low-power physical (PHY) layer. As an overview, the physical layer specifications allow ZigBee devices to operate at one of three bands: 868 MHz (Europe), 915 MHz (North America), and 2.4 GHz (worldwide). The 2.4 GHz band, in which ZigBee transceivers are most commonly deployed, uses the OQPSK (offset quadrature phase-shift keying) modulation stream. This scheme, a derivation of traditional QPSK, is used because it requires less power than similar schemes while achieving the same or better throughput. OQPSK uses a maximum phase transition of 90 degrees from one symbol to the next. This prevents symbol overshoot and requires slightly less transmission power than the traditional QPSK modulations scheme. This design decision, combined with the use of a 5 MHz channel bandwidth enables devices to achieve a data rate of up to 250 kbits/s in a reasonably power-efficient manner. Because ZigBee transceivers are designed for low-power applications, the physical layer is relatively tolerant to significant error. In fact, devices are able to tolerate an error vector magnitude (EVM) of up to 35 percent while maintaining reasonable bit error rate (BER) performance. Thus, design validation and product

request require a variety of test methodologies. This paper examines the reasons why you must conduct specific tests and provides tips to achieve the most accurate testing methodologies.

Public understanding of science and technology is a very important aspect of our modern world. Scientific discoveries and new technologies serve the purpose of pushing back the frontiers of human ignorance and make life and the actual way humans do things much simpler. It is therefore of little use keeping them in laboratories and libraries alone. Information on scientific discoveries and new technologies should be disseminated to the general public so that people can be aware of them and make informed choices. In this project we are aiming to design a system which can detect the theft on power lines, by comparing the input power with output power, this will save the WAPDA money by detecting the theft, moreover the system can also inform the WAPDA office by sending sms through GSM module.

PROBLEM STATEMENT:

For the detection of theft on lines and for checking meters either they are having any fault or not the WAPDA personnel have to visit themselves for keeping an eye on the users to prevent any loss of power in the fating due to which the man power and as well as the expenditure on every visit, may be several times a week is the main issue for WAPDA. Due to the corruption of some lower class WAPDA line men, there was quite difficulty for the Officers to detect where the problem lies, and government has to suffer shortage of power and financial resources. And the WAPDA meter readers have to go first to check the Unit used and then he should have to deliver the bill to every particular user.

AIMS & OBJECTIVES OF THE PROJECT:

- The objective is to detect the theft for saving the WAPDA resources.
- Our second objective is to inform the WAPDA office about the theft on the main line on real time basis.
- The third objective that can help the WAPDA is to take the readings of different meters.

METHODOLOGY:

The methodology to build this system is quite simple the 220V output from the transformer will be given to

Current transformer which measures the current by using ADC, the other part of 220 will be given to different energy meters. All the energy meters also contain C.T for measuring current. Each meter have its own Zigbee, which sends the current information to main unit, the main unit also contains Zigbee which receives the current information from different meters, the main unit adds all the current and compares it with the input current, if the input current does not match with the output then the information about theft will be sent to WAPDA head office, also this information will be displayed on LCD.

EXPERIMENTAL SET UP :

In this Project the transformer will allow the step down power to flow to the two Electricity meters which will measure the Frequency, Amperes, Voltage and will also show the Units down for electricity usage [4]. A GSM Module and Zigbee receiver module will be attached to the main Transformer along with MAIN LCD which will show rating or Transformer power as well as the two Electricity meters attached in this experiment, the Zigbee will receive the data and will send it to the WAPDA through GSM. Along with two electricity meter, Zigbee transmitters are attached which will allow the reading to transmit to main Zigbee receiver attached to the Main Transformer. Each meter will have its own LCD to show readings separately. Fig shown below .

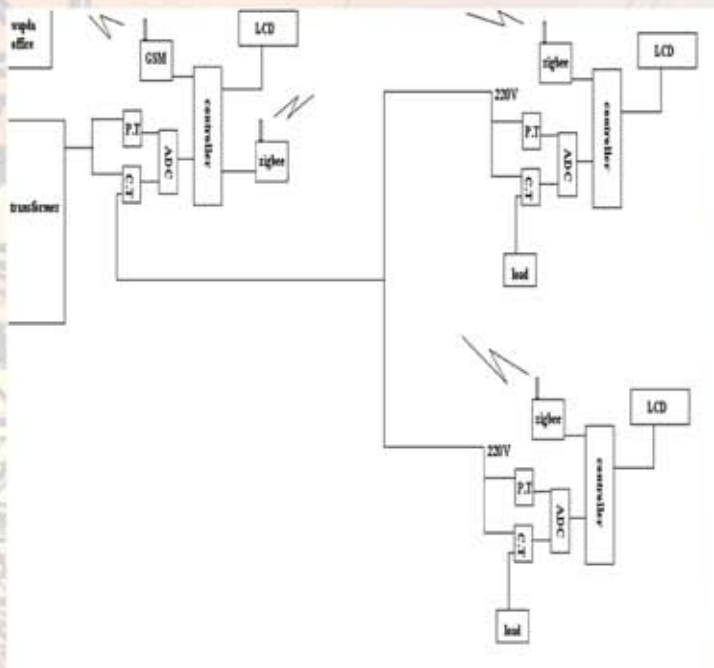

Fig. GSM & ZIGBEE based theft Detection and Monitoring system.

RESULT EXPECTED :

- The theft on power lines can be detected, by comparing the input power with output power, this will save the WAPDA money by detecting the theft, and moreover the system can also inform the WAPDA office by sending sms through GSM module on real time basis.
- Frequency , Amperes, Voltage and Unit usage can be seen on LCDs.

UTILIZATION OF RESEARCH RESULTS:

- Man power can be saved on taking readings from the meters.
- Any disturbance in the Electricity meters can be detected.
- User can access the readings on LCD of their particular meter.
- Any Problem with the Lines can be detected.
- Government expenditure can be saved.

REFERENCES:

- Minnkota Power's Load Management System, accessed 22 August 2009.
- Graeme Gooday The morals of measurement: accuracy, irony, and trust in late Victorian electrical practice, Cambridge University Press, 2004 ISBN 0-521-43098-4, p 232-241
- Electronic devices and circuit theory BY Robert L. Boylestad, ISBN 978-81-317-2529-0
- Whyte, Adam Gowans (1930). Forty Years of Electrical Progress. London: Ernest Benn. pp. 31,159.
- 8051 microcontroller BY Muhammad Ali Mazidi ISBN: 978-81-317-5899-1
- Electrical and electronic technology book
- Power electronics by Ashfaq Ahmad
- Eugenii Katz. "Blathy". People. clarkson. edu. Archived from the original on June 25, 2008. Retrieved 2009-08-04.
- Ricks, G.W.D. This paper appears in: Electrical Engineers, Journal of the Institution of Issue Date: March 1896 Volume: 25 Issue: 120 On page(s): 57 - 77 Digital Object Identifier: 10.1049/jiec-1.1896.0005

CURRICULUM VITAE:

Name: Shahroz khan.

Contact: HAMDARD University Islamabad (Hamdard Institute of Information Technology).

Address: House. No 50, Street 30, G-6/2, Islamabad.

Phone: +92-345-9162655

E-mail: khumaryaan1@yahoo.com

GWIA

GATEWAY TO PROGRESS IN PAKISTAN

(With Especial Focus on Baluchistan)

By: Engr. Abdul Rahim Shaikh
(EX-PCS, Sindh)

The Gwadar deep water port is the third port of Pakistan and is located at the mouth of the Persian Gulf and outside the straits of Hurmooz. The Gwadar port has formally become operational in December 2008. Gwadar, a district of Balochistan enjoys strategic position on the coastline of Pakistan.

BRIEF HISTORICAL REVIEW OF GWADAR PORT

Gwadar port was part of Oman before 1958 and became part of Pakistan on 8th December 1958 on the payment of \$ 3 million to Ruler of Oman. This potential site for deep sea port was first identified by Pakistan in 1954 during the coast line survey by United State Geological Survey (USGS). Gwadar was a deprived small village without basic necessities of life had a population of few thousands. The villages' population is heavily dependent on fishing which hardly fulfill their basic needs of life.

Due to geopolitical and strategic location, the influence of superpower and vested interest of other countries, the government of Pakistan was not in a position to construct the port site almost 30 years i.e. from 1958 to 1988 after the purchase of Gwadar from Oman. A small port project was first started in the year 1988 and completed in 1992 at the cost of Rs. 1.623 billion. The technical and financial feasibility study for a major deep sea Port was initiated after 1993.

INTERNATIONAL IMPORTANCE

Gwadar has its own and unique strategic location, located on the western end of deprived and stone-age Baluchistan province of Pakistan and opposite end of Gulf of Oman. Gwadar port is biggest competitor of United Arab Emirates Ports and Charbahar port of Iran. Gwadar could serve as an alternate route for trade between East Asia through the Indian Ocean and Western Asia, best when shipping routes through the Strait Malacca could be blocked by US. Gwadar has the potential to acquire the status of a center piece as a gate to Strait of Hormuz. Through Gwadar, by improving the exiting links and infrastructure to Caspian Region, and means a better trade route to the land locked Caspian Region and also has a great potential to become a regional hub and a trans-shipment port in the future.

It is an important route for oil tankers bound for East Asian countries like Japan, Korea and western countries out of Gulf. Gwadar port provides an overland trade route to western China and Central Asia via Afghanistan which will drastically cut down the transportation time at very low cost of transportation means very cheap traded goods to China and Central Asian countries.

In military and strategic terms, Gwadar will be a new avenue for Pakistan Navy as compared to the Karachi which is nearly located to the Indian borders and twice attacked during wars with traditional rival India. In case of handing over the port to China it will serve as Watch Dog in the region especially for India. India already showed its deep concern when Pakistan signed a contract with China to hand the Port. Gwadar could potentially be used to as a monitoring station and listening post for observing the sea-lanes from the Persian Gulf to a full-fledged foreign naval.

CONSTRUCTION

Gwadar deep sea port has two phases, Phase I was completed at the cost of USD \$ 248 million during the period 22nd march 2002 to December 2006 and inaugurated by former President General Musharraf on 20th march 2007. Phase II is under construction will be completed soon. The berths capacity at phase I has Bulk carriers of 30,000

construction Phase II has one bulk Cargo terminal capacity of 100,000 DWT ships, one Grain and one Ro-Ro terminal.

PROJECT DEVELOPMENT PLAN

Master Development Plan of Gwadar Deep Sea Port includes development of an area over 18,600 hectares of land for various project schemes and structures including:-

- Expansion of port over an area of 400 hectares.
- Export Processing Zone of 47000 acres located on land adjacent to the port in East Bay.
- Special Industrial Zone of about 4,000 hectares lying to the north of the town.
- Oil refinery of 1,000 hectares located to the north east of the town.
- Residential area of 400 hectares stretching north of the existing town along Western Bay.

UPDATE OF PROJECT

Gwadar Port is owned by the government-owned Gwadar Port Authority and operated by state-run Chinese firm China Overseas Port Holding Company (COPHC). Earlier it was operated by PSA International (2007-2012). Pakistan on 18th Feb, 2013 formally awarded a multi-billion dollars contract for construction and operation of Gwadar Port to China. As per the contract, the port will remain the property of Pakistan but would be operated by the state-run Chinese firm, China

Brief Description of Gwadar Port Phases given below in the Table.1

S. No.	Parameters	Phase I	Phase II
1	Cost	USD \$248 million	USD \$932 million
2	Duration	2002-2006(Completed)	2007– Present
3	Berths	3 Multipurpose Berths	4 Container Berths
4	Approach Channels	4.5 km long dredged to 12.5m depth	To be dredged to 14.5m depth
5	Oil Terminal	--	2 Oil Terminals (capacity: 200,000 DWT ships each)

Dead Weight Tonnage (DWT) and container vessels of 25,000 DWT with length of berths of 602 meters along with 100 m service berth. Turing basin of 450 m diameter along with important port infrastructure i.e. handling equipment, pilot boats, tugs survey vessels etc. Under

Overseas Port Holding Company (COPHC).

The contract signing ceremony was held on 18th Feb, 2013 in Islamabad and was attended by President Asif Ali Zardari Chinese Ambassador Liu Jian, some Federal Ministers,

Gwadar was a deprived small village without basic necessities of life had a population of few thousands. The villages' population is heavily dependent on fishing which hardly fulfill their basic needs of life.



members of parliament and senior government officials. The ceremony was actually held to mark the transfer of the concession agreement from the PSA (Port of Singapore Authority) to the COPHC.

On 11th October, 2013, Pakistan's Minister for Ports & Shipping, Kamran Michael announced that Gwadar port will be operational in 5 months period.

OTHER PORTS OF PAKISTAN

Port Qasim (PQ) and the newly developed port at Gwadar and KPT are the premier ports of Pakistan, handling major portion of the entire national trade. Since 2003-04, the port handles on an average 65% of total Pakistan's trade. In view of increasing traffic at the ports, a number of projects have been envisioned for phased implementation on a BOT basis.

Port Qasim is the second deep sea port of Pakistan. It is fast becoming a major contributor to the national trade economy of Pakistan. On an average the port is handling almost 35% of total trade since 2003-04. Qasim International Terminal Limited (QICT) is operating at Port Qasim on BOT basis.

PORTS MANAGEMENT AND CAPACITY UTILIZATION

QICT is a foreign consortium of P&O Ports and Mackinnon Pakistan Limited. QICT is closer to vital up-country markets from where major exports are originated. Currently, it can

handle more than 600,000 TEUs per annum and is considering the expansion plan of 1.175m TEUs in three phases, increasing the overall capacity to 2.175 million TEUs per annum. In 2008 QICT recorded a container volume throughput of about 764,000 TEUs, making it presently the largest such terminal in terms of TEUs handling in Pakistan.

KICT was the first international container terminal operator established at the Karachi Port. It is a member of the Hutchison Port Holdings (HPH) Group. In 2008, the total container handling volume by KICT was about 621,000 TEUs. Currently, KICT is also planning a major expansion to increase its handling capacity to 750,000 TEUs per annum. PICT has been setup on a BOT basis, providing container handling services at Karachi Port to a large number of international shipping lines. The dedicated area for the terminal is 220,000 square meters. Amongst the present container terminals in Pakistan, PICT has the deepest designed berths. It is the only terminal in Pakistan, sponsored and owned by local groups and the only port infrastructure project listed on Karachi Stock Exchange (KSE). PICT is financed by International Finance Corporation (IFC), the private sector arm of the World Bank, in collaboration with OPEC Fund for International Development (OFID).

CHINA: THE MAJOR BENEFICIARY

The development of Gwadar port will not only benefit the Pakistan it will benefit the whole region. This trade route

will benefit China and land lock Central Asia Republics (CARs). The dependence of China in terms of oil from gulf region is very high. The route strait of Malacca which is very long is under the influence of US and US could block the route whenever required. China have huge area of world's land but doesn't have any port of hot waters which they can use whole year. The Chinese industrial approach to Xinjiang province (Western China) via Shanghai port (Eastern China) is an approximately 16000 km and the sea travel of around 2 months, incur huge transportation cost as well as duties and taxes. Gwadar, as compared to the other route has only distance of 2500 Km from China and port may work throughout the year because of hot water. After this oil has reached the Shanghai or the Chinese East Coast, it has to be transported thousands of miles in land to West of China. By using Gwadar port and then

Karakoram Highway (KKH) is much safer, cheaper and shorter route to west of china. In fact the china is major beneficiary of this Gwadar project beside Pakistan.

Table 2 shows that China is the biggest Oil Consumption Country in the whole ASIA PACIFIC region which is 32.34% of the total ASIA PACIFIC region. Its Total Consumption 10221000 barrels per day almost 3731 million barrels per annum last year with the growth of almost 5% last year. The consumption share of china in the world total consumption is 11.7% which is second highest consumption of an individual country after USA. USA has the highest oil consumption in the world i.e. 18555000 barrels per day which 19.8% of the total world consumption.

Table 2 shows the country wise oil consumption in the ASIA PACIFIC region

Total Oil consumption of Asia Pacific Region									
In Thousand barrels Per Day	2006	2007	2008	2009	2010	2011	2012	Change over 2011	2012 Share of total
Australia	929	936	49	43	62	007	019	.9%	1.1%
Bangladesh	89	86	4	8	6	08	14	.3%	0.1%
China	7439	7823	947	229	272	750	0221	.0%	11.7%
China Hong Kong SAR	305	324	93	34	62	64	60	1.2%	0.4%
India	2737	2941	077	237	319	488	652	.0%	4.2%
Indonesia	1234	1271	263	316	426	549	565	.4%	1.7%
Japan	5210	5053	882	429	473	465	714	.3%	5.3%
Malaysia	615	672	61	62	72	82	97	.1%	0.7%
New Zealand	153	154	54	48	50	49	49	0.1%	0.2%
Pakistan	354	387	88	14	11	17	02	4.2%	0.5%
Philippines	284	301	66	83	86	79	82	.7%	0.3%
Singapore	884	963	015	083	193	246	255	.4%	1.6%
South Korea	2320	2399	308	339	370	394	458	.5%	2.6%
Taiwan	1043	1096	92	87	028	51	39	1.8%	1.0%
Thailand	973	984	94	071	076	171	212	.6%	1.3%
Vietnam	254	283	00	04	29	58	61	.7%	0.4%
Other Asia Pacific	302	317	07	49	51	76	82	.3%	0.4%
Total Asia Pacific	25124	25989	5881	6205	7766	8754	9781	.7%	33.6%
Total World	85138	86575	6052	5064	7833	8879	9774	.9%	100.0%

The Japan and Korea in East Asian region is potential client of china for the refined petroleum product. Japan has consumption of 4714000 barrels per day which is 5.3 % of the world consumption and South Korea has 2458000 barrels per day which is 2.6% of the world share. China, Japan and South Korea all-together have 17393000 barrels per day consumption which is 58.40% of ASIA PACIFIC region and 19.6% of total world consumption with an average growth of 4.6 % last year. This high percentage growth shows the consumption of oil in these countries will increase very sharply as compare to the other countries of this region.

of oil and high growth in the oil consumption of these countries shows a great potential of transportation of oil via Gwadar port and it may grow by the time in coming years.

The import and export of crude oil and oil products are given in the table below.

Above tables shows China as is 2nd largest oil importing country after USA its total import is 7162000 barrels per in which crude oil is 5433000 and oil product are 1729000 barrels per day. China Imported 7162000 barrels oil and its product

Table 3 shows the Import and Export of Crude oil and Oil products

Oil: Imports and Exports 2012				
	Thousand barrels daily			
	Crude Imports	Product Imports	Crude Exports	Product Exports
US	8491	2096	23	2657
Canada	514	211	2437	619
Mexico	‡	581	1290	76
S. & Cent. America	392	1411	3143	691
Europe	9512	2976	383	1791
Former Soviet Union	‡	114	6049	2548
Middle East	222	559	17646	2053
North Africa	186	312	2139	465
West Africa	‡	238	4328	235
East & Southern Africa	285	260	86	15
Australasia	575	379	272	164
China	5433	1729	26	538
India	3547	323	‡	1349
Japan	3739	1004	‡	221
Singapore	948	2016	12	1479
Other Asia Pacific	4755	2505	767	1813
Total World	38599	16715	38599	16715

Source: Statistical Review of world Energy 2013-workbook

out of their total consumption of 10221000 barrels/day last year. Total import of China is 70.07% of its total consumption. Japan don't have their own production of oil that why imported almost 100% from different countries of which more than 75% were imported from Middle East. Above data shows the potential for Gwadar Port a very huge size of business in the shape of transportation of oil

and its product besides the trading of goods and other business from Central Asian Republics.

COST MATRIX

The calculation of cost estimation is complex in this scenario. No exact cost is given or calculated in case of this new route i.e. from Middle East to Chinese province, Xinjiang via Gwadar, Pakistan, however few sample estimates are available from secondary source which will use in this section to calculate the benefits from oil trading from this new route. Figure below indicate the route from Gwadar to Kashgar.



According to Erickson and other "Two important considerations should be noted while examining the cost. The first is that the approximations are based on publicly

Table 4. INTER-AREA MOVEMENT OF OIL(ALL REGIONS)

From	To													
	US	Canada	Mexico	S. & Cent. America	Europe	Africa	Australasia	China	India	Japan	Singapore	Other Asia Pacific	Rest of World	Total
Thousand barrels daily														
US	-	162	495	934	601	77	4	125	18	102	122	19	22	2680
Canada	2955	-	-	4	55	‡	‡	30	‡	13	‡	‡	-	3056
Mexico	1031	25	-	21	188	-	-	22	75	‡	2	1	-	1366
S. & Cent. America	1978	14	14	-	424	7	-	636	455	33	226	45	1	3834
Europe	555	123	54	165	-	473	4	21	6	18	225	279	251	2174
Former Soviet Union	545	5	-	27	5792	64	25	1215	49	187	141	342	205	8597
Middle East	2163	155	12	124	2261	425	133	2900	2474	3543	1119	4385	6	19699
North Africa	341	149	-	88	1577	-	26	221	89	18	8	68	17	2604
West Africa	861	84	-	192	1313	-	119	1033	548	98	2	315	-	4564
East & Southern Africa	1	-	-	8	1	-	‡	59	4	12	12	2	-	100
Australasia	6	-	-	8	1	‡	-	157	5	60	53	145	1	436
China	3	2	-	115	13	21	1	-	10	10	52	311	26	564
India	40	2	-	89	169	177	3	11	-	60	210	248	340	1349
Japan	-	1	3	2	2	-	34	37	3	-	72	68	‡	221
Singapore	2	3	-	2	23	11	233	140	32	8	-	1031	6	1491
Other Asia Pacific	106	-	3	25	70	26	372	556	103	581	717	-	21	2580
Total Imports	10587	725	581	1803	12488	1281	954	7162	3871	4743	2963	7259	896	55314

++ less than 0.5; + less than 0.05

available estimates and, therefore, should not be treated as exact estimates but rather as secondary estimates. Secondly, the numbers that are represented in the table below, while being approximations, give an indicative picture of what the costs involved are, and it is important to focus on the obvious highlights”

Table 5 Sample Oil Transport Costs to China

Mode	Cost (USD/barrels)	Cost (USD/barrels/1000km)
Tanker	1.25	0.18
Pipeline	2.41	0.75
Train	7.19	7.19

1. Based on VLCC carrying 2,000,000 barrels of oil (Maritime Connector)
 2. Shipping costs = \$0.18/barrel/km (Erickson & Collins, 2010)
 3. Pipeline costs = \$0.75/barrel/1000km (Erickson & Collins, 2010)

Source: Erickson, A.S., Collins, Gabriel, "China's Oil Security Pipedream: The Reality, and Strategic Consequences, of Seaborne Imports", Naval War College, Newport, 2010

Table 5 is reproduced from Erickson and other's calculation just to highlight the different type of cost involved i.e. through Sea, Pipeline and Train. Finally the average shipping cost \$0.18/Barrel/1000km and trough pipeline cost is calculated as \$0.75/Barrel/1000km. Transportation through train is most costly option. It is therefore option through sea and pipe line is used in calculations.

CONCLUSION

The checkered history of relationship between Centre and Baluchistan reflects an extended account of political inaptitude, economic exploitation and unfulfilled promises. State, being the major runner of the national affairs, is to be held responsible more than anyone else, for the crisis. Centre, in its successive policies and measures, overlooked the sociological and anthropological peculiarities of the people of Baluchistan and the resultant economic deprivation which has haunted their lives for too long. Above all, the sheer disregard to the development needs of the province created a feeling of despair among the local people. Moreover, the potential of Gwadar rains far from exploited despite the fact that its growth may well lubricate the engine for the development of Balochistan which may ultimately

offer to the country, very similar to what, Karachi, as a port city and economic hub offered to Pakistan in terms of economic prosperity.

The paper specifically focused on the benefits gained from the trans-shipment of oil and other traded goods from and to China and other Central Asian Countries. It was convincingly evident from the paper that from the trans-shipment of oil for China alone may result in saving of billions of dollars. Trade with the Central Asian Countries and enticing China to share a portion of these benefits with Pakistan will result in the earning of billions of dollar per year. Besides this, development of infrastructure and industrial zone will surely reduce the unemployment in region and raise the standard of living of the province.

There is a need to develop state of the art port facilities to run the port in competition with ports of Dubai, Singapore, Hong Kong etc. Develop a new trade policy in special context to trade from Gwadar port. Develop a comprehensive Transit trade policy as Gwadar port will be the major transshipment site of the region. Comprehensive industrialization policy for Balochistan focusing on the diversified use of the port.

FDI policy for Balochistan province to attract the foreign direct investment. Government also needs to accord a high priority to the law and order situation in the province to take benefit of such port.

Conclusively, there are good reasons to be optimistic about Baluchistan's development. While much remains to be done, the province is already transforming for the better, and these changes will bring about timely and laudable improvements in the lives of its population. As for now, the crucial challenge is to learn from the successes and failures of the past, draw clear lessons, and improvise on policies to move Balochistan, once and for all, from the periphery to the core of economic development for the benefit of its people.

Engineers ... are not mere technicians and should not approve or lend their name to any project that does not promise to be beneficent to man and the advancement of civilization

- John Fowler

LAC [Pvt] Ltd.

ENGINEERS & CONTRACTORS



LAC House - 465, Street No.5, Main Market
Gulrez-II, Rawalpindi, Pakistan
Ph: +92 51 5596003 - 4307388
Fax: +92 51 5596543 E-mail: lac465@yahoo.com

www.lac.com.pk

Spacecrafts

A space craft can be generically defined as a vehicle designed to fly in outer space. Different spacecrafts perform different tasks in space, but they can be broadly classified into unmanned and manned space travel.

Unmanned space travel consists of Orbiters, Rovers, Landers and Flyby.

Orbiters are the ones that move around different planets.

Earth orbiting satellites serve for many purposes including communication, earth observation, navigation, weather monitoring, disaster management, military applications, etc.

Lander is the space vehicle that lands on an astronomical body for example lunar Lander that has landed on the surface of our moon.

Rovers are robotic vehicles that move on the surface of the planet and perform designated tasks. Flyby is a space probe which flies by an astronomical body while gathering useful information.

Every spacecraft regardless of its type and purpose consists of some subsystems, all of which combine together to formulate a working spacecraft. These subsystems are generally the following:

- Attitude & Orbit Control Subsystem (AOCS)
- Telemetry, tracking & command Subsystem (TT&C)
- Propulsion Subsystem

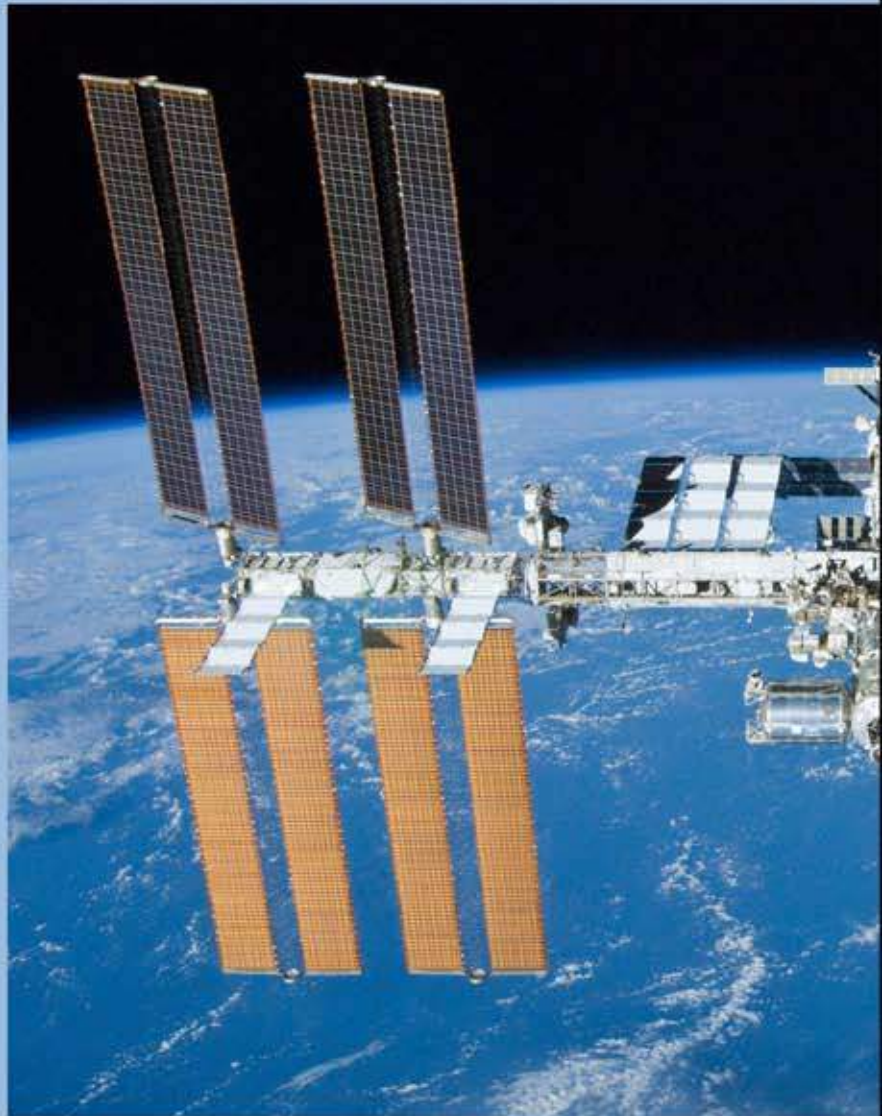

Solar Panel

Low cost, low mass alternative to mechanically deployed space structures.

& Inflatable

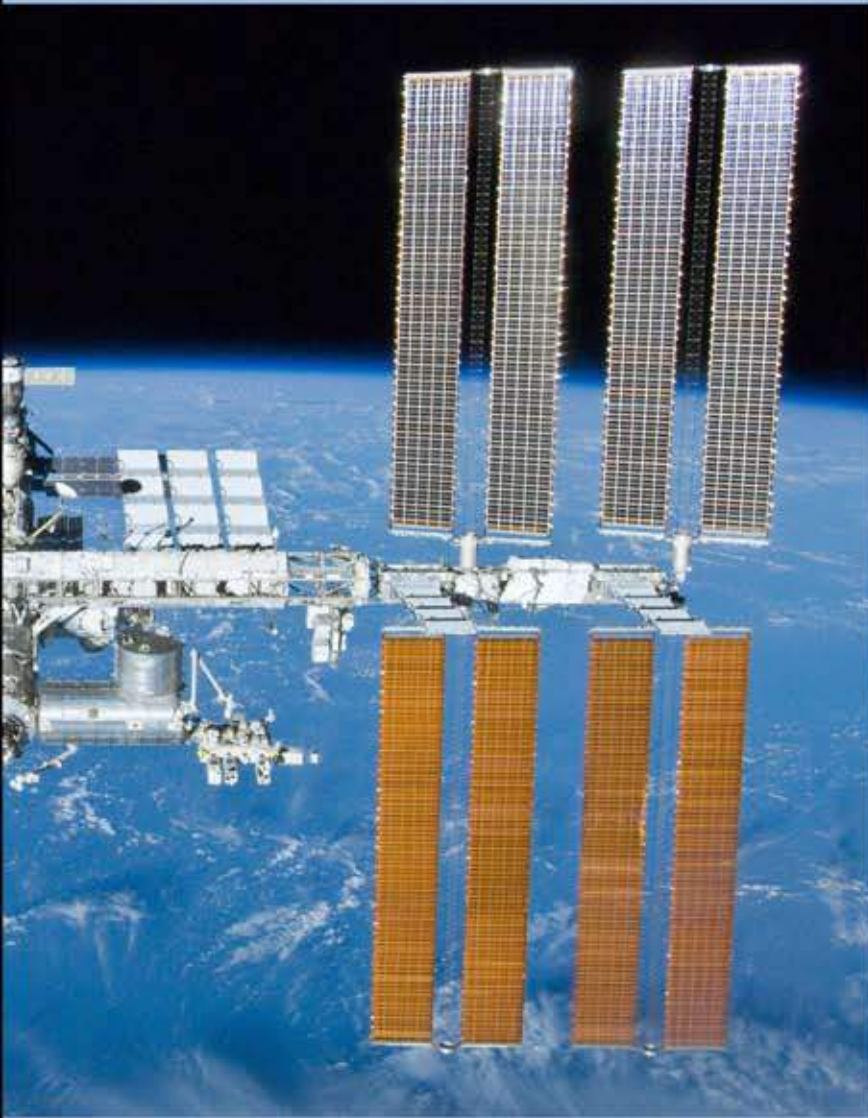

- Electrical Power Subsystem (EPS)
- Thermal Subsystem
- Structure Subsystem
- Payload Subsystem

Each subsystem is equally important and significant in its own way, but the power subsystem plays the most crucial role in the spacecraft design, development and in-space performance.

The electrical power subsystem of any spacecraft comprises of a power source, conversion system, storage units, power distribution system and power regulation and control system. It provides, manages and controls power supply to all the other subsystems and every single component on board.

In most of the earth orbiting and inner solar system missions, solar energy has been the primary source for power generation. Spacecrafts fetch solar energy through mounted solar panels and the on board conversion system converts this energy into electrical power using the photoelectric effect, to operate all the components of the spacecraft.

Considering the increasing trend in small satellite environment, low cost and high performance are the two key features that determine the mission's success. EPS subsystem plays a major role in this regard as solar panels being the only feasible method of power generation happens to be heavy and costly. Therefore, scientists and engineers continue finding methods to

Technology

By Engr. Syeda Masuma Fatima Zaidi.

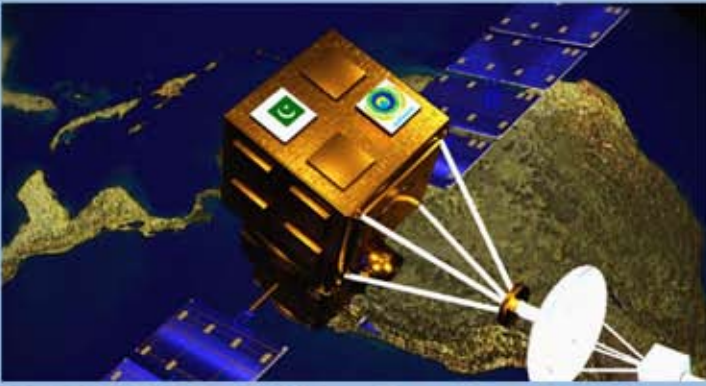

PAK-SAT 1R: Pakistan's communication satellite (courtesy SUPARCO)

produce lighter panels with good efficiency and low costs. This research area is called gossamer structures.

The term gossamer structure refers to the general category of space ultra-low-mass structures, such as inflatables and many other forms of expandables. A space inflatable structure is a specific application of a membrane (highly flexible plate or shell like elements) structure. This usually implies thin, low modulus materials such as polymer films. With the advent of this new space technology, applications such as Mars rover solar arrays, Satellite blanket solar arrays, solar concentrators, etc have been envisioned and developed and inflatable solar arrays came out as the most promising candidate for further development to advance state of the art EPS and structure subsystem of the spacecraft.

The advantages of using such panels are reduced stowage volume and mass, increased specific power (greater than 100 W/kg) and reduced cost over current mechanically deployed solar arrays. These solar panels are particularly attractive for missions that demand high power output with launch vehicle size restrictions.



MER Lander (Courtesy NASA/JPL/Caltech)

The following information gives us some insight about the ongoing work in the said field.

- **JPL ST4 Inflatable Solar Array:**

The ST4 inflatable solar array is a 3 meter by 15 meter array capable of producing of 6kW power. The basic configuration includes Solar Array Blanket, Structural Support Components, Controlled Deployment System and Inflating System.

- **TELEDESIC Inflatable Solar Array:**

This program envisions a constellation of 288 satellites in LEO to provide high data rate communication. An inflatable structure is designed to support a 3 meter by 10 meter solar array with \$100/W cost target.

- **MARS Rover Inflatable Solar Array:**



Teledesic Inflatable Solar Array

This concept utilizes 1.5 meter deployable wheels and an inflatable solar array to cover vast surface area in rapid times. It can hence be concluded that inflatable solar array technology continues to mature and expand the possibilities for large-scale satellite solar arrays as well as planetary surface arrays for rover use. Technology advancements in inflatable rigid structures and controlled deployment systems, in conjunction with advancements in solar cell technology have lead to increase in specific power, reductions in system cost and minimization of package volume for solar arrays. Lab and thermal vacuum chamber demonstrations of this technology have shown the viability of the approach. The flight demonstration of the ST4 solar array will provide the necessary flight heritage to allow the use of this technology for future deep space and commercial missions.

For feedback & comments

sheikhmukhtar@hotmail.com, engrhab@gmail.com
makhan613@gmail.com, pr@pec.org.pk

MUNICIPAL WASTEWATER TREATMENT FOR IRRIGATION

Today the most immediate and the highest environmental issues of the world are degrading catchment and water shortage. The most populated part of the world is human which impacts on fresh water. In Pakistan the industrial sector is adding surface as well as groundwater qualities by extensively diffusing their effluents into streams, watercourses, agricultural lands, rivers, lakes and ocean that are hazardous effects on human health apart from threatening the quality of water. Therefore, the effluents are added into the water storages causing surface and groundwater pollution which are threatening human and animal health, agriculture area and other ecosystems. In Pakistan, little municipal wastewater treatment facilities are available. Gujranwala is a 3rd biggest industrial city of Pakistan. In the city, most of the local drains are unlined and uncovered, seepage causes the ground water contamination and the bad fume disturb environment. Disposal of untreated municipal wastewater into drains and finally into canal and rivers, deteriorate the water quality of the water body and harmful for aquatic life (fish culture), change the structure of agro-land by adding the heavy metals, detergent, chemicals etc. The present study is based on chemical analysis of municipal wastewater not biological analysis and to investigate quality status of effluents from Gujranwala and to produce an effluent that can be safely discharged into inland or sea waters. The study also involves for helping city planner to make water and sewage policies. A field survey was conducted and sampling was done from different points of the municipal drain Gujranwala. The values of Sodium Absorption Ratio (SAR), Residual Sodium Bicarbonate (RSC), Total Suspended Solids (TSS), Total Dissolved Solids (TDS), pH, Turbidity, Electrical Conductivity (EC), Chloride (Cl^{-}), Carbonates (CO_3^{2-}) and Bicarbonates (HCO_3^{-}) measured and compared with National Environmental Quality Standards (NEQS) to check the water quality. According to NEQS all the samples were unfit for irrigation purpose. To make the wastewater fit for irrigation the chemical treatment of wastewater was done and again compared water quality parameters with NEQS. Based upon the results it is recommended, wastewater treatment plants should be installed to make water clean and fit for irrigation.





By: Engr. Hasan Ali Mira
(Hamdard University)

UNDERWATER ACOUSTIC COMMUNICATION

Since the last century, there is an ever increasing demand of an efficient, reliable and an even better communication system in both air and underwater. Projects like “Underwater Acoustic Communication”, provides an inspiration and corroboration to overcome those intensified modern desires of technology.

What is Underwater Acoustic Communication?

It is about wireless communication in underwater, where data is transmitted through a Piezo transducer in underwater in terms of sound, which is then received by hydrophone wirelessly. The received acoustic data will be processed, analyzed and simulated to remove the ambient noises and multipath propagation effects of the underwater environment.

Scope

The need for underwater wireless communications exists in applications such as remote control in off shore oil industry, pollution monitoring in environmental systems, seismic monitoring, collection of scientific data recorded at ocean-bottom stations, speech transmission between divers, mapping of the ocean floor for detection of objects, unobstructed operation

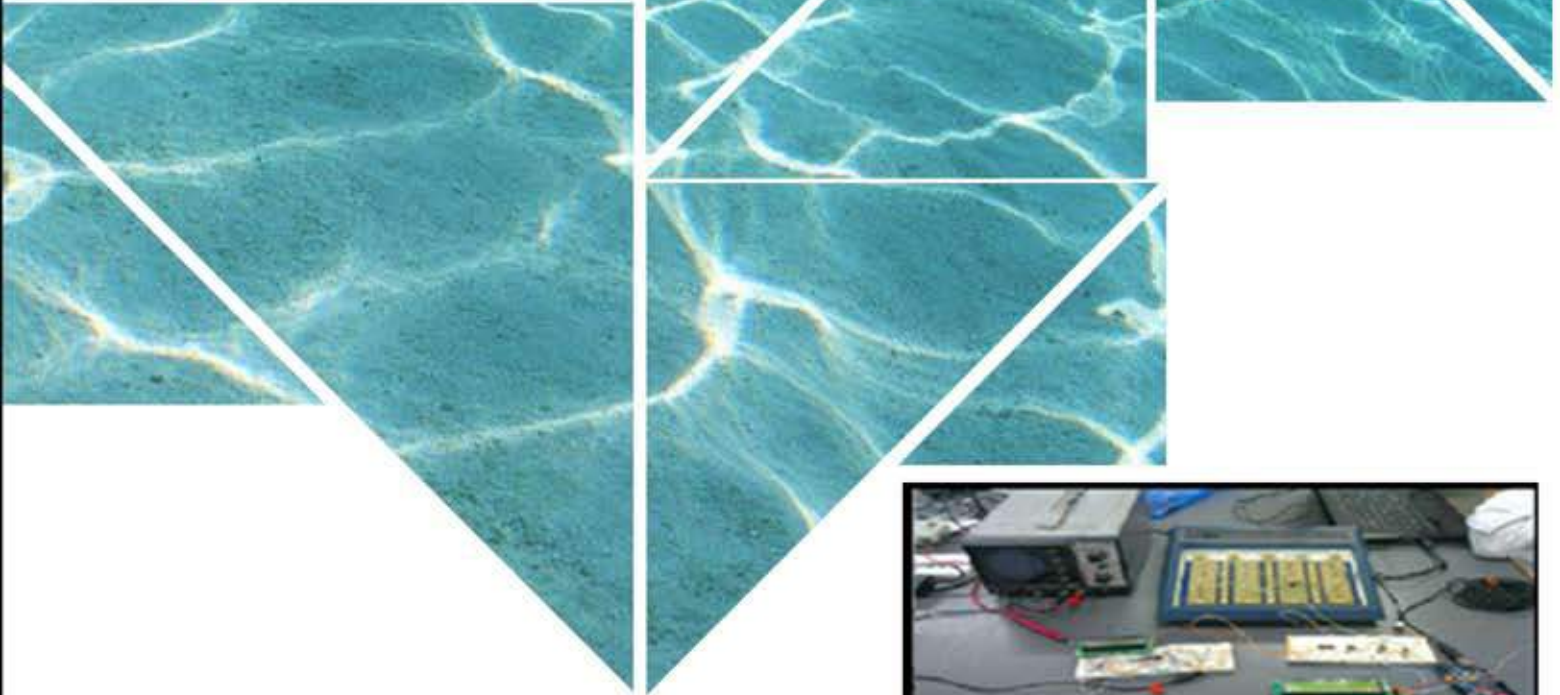
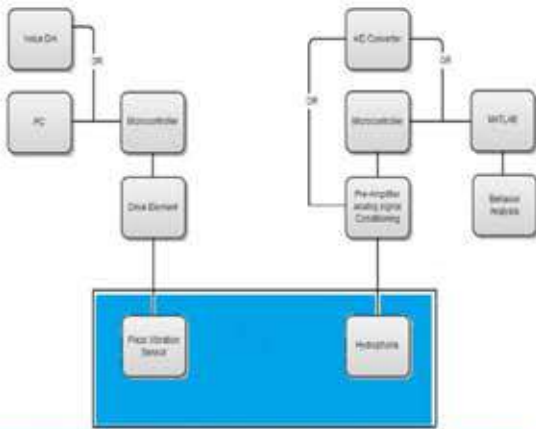

of unmanned or autonomous underwater vehicles (UUVs, AUVs), voice processing of underwater living things (i.e. fishes etc) as well as for the discovery of new resources.

Technology Used

Since sound is the only quantity that travels underwater, here, Morse code serves as an efficient technique to transmit textual data in terms of sound through Piezo transducers. It also provides data encryption facility. Standard delays are relatively easier to implement with and to synchronize both the transmitter and the receiver. Indeed, better designing filters will help to reduce much of the ambient noises. For data analysis, Elliptical filters give the best possible output to the users. Since it is designed for audio signals, has equal passband and stopband ripples and are always stable.

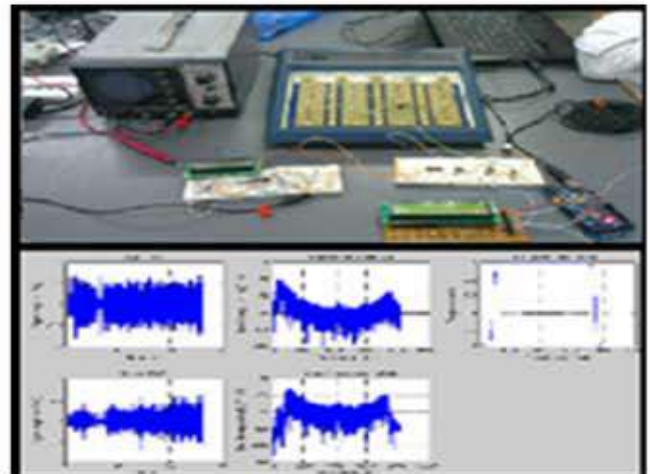



Sh. Safder Ali & Co. (Pvt) Ltd.

ENGINEERS & CONTRACTORS

H. No. 13, St. No. 103 Housing Colony No. 1, Toba Tak Sing, Pakistan.
Tel: 046-2510550 Mobile: 0300-6569200



SPIRAL WELDED STEEL PIPE



POLYETHYLENE PIPE

Karachi Office
505, 506 Al-Khaleej Tower, Plot # 24/3,
BMCHS, Shaheed-e-Millat Road,
Karachi
P | 021-34922639, 021-34922640, 021-34922642
F | 021-34922643
E | info@hitechpipe.com

Factory
Plot # X-22, Extenseion Area, S.I.T.E, Kotri,
Sindh, Pakistan
P | 022-3870614
F | 022-3870606
E | info@hitechpipe.com



CONTROLLING OBJECTS THROUGH

By: Engr. MUHAMMAD SHAKEEB



IMAGE PROCESSING

As we know that now a days It's an era of virtual reality and a lot of electronic equipment's can detect motion of its surrounding and perform various desire task. As all these types of technologies work on the principles of Image Processing and some sort of fast processing device . Image Processing is a method in which Input is an image that is to be processed by some algorithms.

Certain algorithms are implemented through some software programming. The software selection is mainly based on the hardware device on which image processing algorithm is to be implemented.

I want to discuss basic principle of image processing used in newer technologies Many examples for such type of image processing are: Xbox Kinect Simulator , Samsung Smart T.V, Air Gesture Mobiles etc.



The work which I want to describe you is basically Movement of pointer through the movement of your hand. Wherever you move your hand the pointer on the screen is moved accordingly.

Real time image processing needs fast processing .The device which is used for image processing is FPGA (Field Programmable Gate Array) kit which is the basic hardware for implementing this task.

Following are the components used to move mouse pointer on screen through image processing.

1. Hardware

- × Camera (High Resolution Camera)
- × Monitor/ LCD (Screen)
- × FPGA Kit (Altera DE2-115 Cyclone IV)

2. Software

- × Quartus II (Programming on Verilog/VHDL)

Hardware :

Digital camera captures the image and pass to FPGA kit through AV cable and the output of FPGA kit is pass through VGA cable to Monitor.

The input image is (Moving Hand) which is processed in FPGA kit that performs certain algorithm which we define in our programming through software and after processing of these algorithms it displays on Screen . Altera DE2-115 board is connected with VGA through SVGA monitor cable.

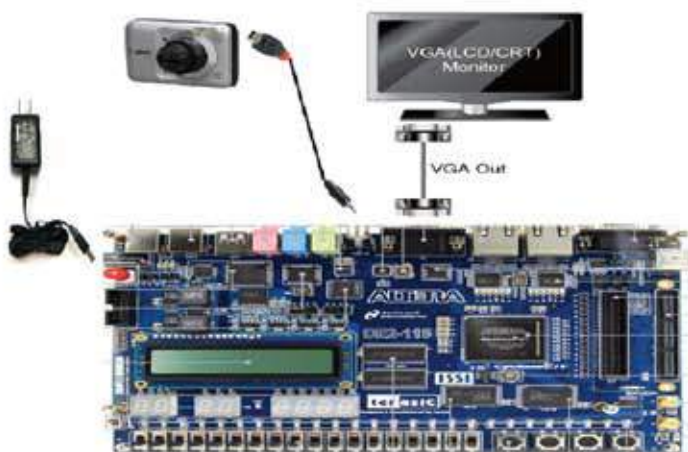

Software Flow:

Quartus software is used for image processing in the starting we interface the camera with the FPGA kit.The board (Altera DE2-115) is equipped with analogue device TV decoder chip which detects and convert the analogue signal (NTSC, PAL) from camera



The work which I want to describe you is basically Movement of pointer through the movement of your hand.

image to binary format.All these Bit streams are stored in the FPGA processor to compare their old image to newer image. Performs various algorithms as in Flow chart below and gives output from a VGA controller block which generates VGA signals (both horizontal and vertical to enable the display on the Screen).

Applications & Features:

By further enhancement such type of projects

- × Can be used as motion detection in surrounding.
- × Can be used for gaming purpose.
- × Virtual mouse.

Conclusion:

× Image Processing on personal computer is relatively slow So, by adding FPGA the response time becomes fast and the pointer movement has fast response.

× This type of projects is the next generation of electronics. It provides wireless and virtual mouse concept.

× The real time image processing on FPGA is now becoming popular in automotive, industries, security and even for fun.

× Virtual mouse exclude the disadvantages of wired devices. It can also provide fun for gamers.



Rimtaj Industries MG (Pvt.) Ltd. is one of the leading companies in the Engineering Industry. We provide Services in the fields of **Engineering Design, Manufacturing, Fabrication & Installation, etc.** to a wide variety of industries. Our company is headed by **Engr. Mahmood Husain** (Chartered Structural Engineer from UK in 1955) as **Founder & Chairman**, having more than 50 years of experience of Engineering & Management in the Engineering Industry and **Engr. Sajjad Husain** (B.Sc Hons in Mechanical Engg. from Pakistan & MBA from USA) as **CEO**. **Engr. Mahmood Husain** in recognition of his high profile of technical and commercial services was elected as an honorable member of "International Who's Who of Professionals" for the year 1998 by "The Ultimate Professional Directory". The Management & Personnel of our company have an experience of more than 30 years in the business. Our skilled personnel have very vast experience of handling multifarious jobs with speed and precision. Objective of our company is to pursue a policy of development in all its related spheres and diversify its production. Our Company is ISO 9001-2008 Certified. Also, it is a registered Industrial Unit with Pakistan Engineering Council (PEC), Lahore Chamber of Commerce & Industries (LCCI), Directorate of Labour, Sales Tax & Income Tax Departments and Associations like PAAPAM and CAP.

Services Available:

Engineering, Designing, Manufacturing, Fabrication,
Erection / Installation, Commissioning, Sub-contracting, etc.

Turnkey Jobs:

such as Oil Blending Plant, where the Scope of Works involves all works including Civil, Structural, Mechanical, Electrical, etc.

Manufactured Items:

- Tractor / Auto Parts
- Agriculture Implements
- Mechanical Parts

Material Handling Equipment:

- Cranes (Overhead, Gantry, Jib, etc.)

General Machinery

Flour Mill Machinery

Fabricated Items:

- Fuel Storage Tanks: Horizontal / Vertical Tanks.
- Steel Pressure Vessels.
- Steel Canopies for Petrol Stations.
- Industrial Steel Buildings with Cranes
- Pre-Fabricated Steel Houses
- Industrial Plant Equipment and Structures.
- Pole-Plants-Moulds with Machinery and Gantry Cranes.
- Canal Regulator Gates & Barrage Gates.
- Sub-Station Steel Structures / Transmission Towers
- Telecom Towers
- Miscellaneous Steel Fabricated Items.



Views/Opinions Of Our Members About PEC Magazine

I appreciate the team working for the magazine. PEC is really doing a valuable work for engineers especially Continuing Professional Development (CPD) courses are very informative and interesting. All other activities organized by PEC are also up to mark, the events which were arranged by PEC in Hyderabad and Sukkur left a remarkable influence on engineers. I personally want to advise other engineers to attend Pakistan Engineering Council seminars and CPD courses that will give you much more information and skills regarding engineering field.

Engr. Syeda Neelam Tahir

The overall material published in the PEC magazine is very interesting and knowledgeable for the people related to engineering field. It has all the things necessary for a good publication with the relevant field. All dynamic activities of PEC are remarkable. I am very impressed with the challenging aspect of PEC and am eager to learn more about the consulting work you are doing in engineering field.

Engr. Muhammad Azeem

Under the guidance of the honorable Chairman, Engr. Syed Abdul Qadir Shah, the honorable Vice Chairman, Engr. Makhtar A. Sheikh and with the efforts of the entire governing body members, the Pakistan Engineering Council (PEC) has evolved as a one-stop assistance and guidance platform for all engineers, fresh graduates as well as experienced professionals, throughout Pakistan.

The CPD activities organized by PEC throughout the country have helped in the professional development and awareness of the engineering community. The short courses specially the technical sessions enhanced the technical orientation and provided an opportunity of exposure with ample amount of knowledge and interaction with different mindsets.

The dynamic work done by the PR committee is inspirational and worth appreciating. They achieved the objective of bringing the opportunities to our doorsteps in such a short interval of time. None of the area was left undone, engineering internships, job opportunities, timely information and guidance on international employment, service structure for the engineers, social activities, seminars, workshops, training sessions, bridging the gap between the practical world and engineering students, PEC not only did it all but did it with great sense of responsibility, dedication and efficiency.

The event held at Sir Syed University of Engineering & Technology, Karachi in which the UAE Commercial Attaché delivered a lecture on different job prospects in UAE, left a remarkable influence on the final year students and I myself witnessed awakening of a new zeal and built up of new confidence in them. All in all, PEC provokes us to recognize and enhance the capabilities within us and provides hope, vision, path and practical guidance not only to fulfill our dreams but to evolve as a better native and benefit our country. On behalf of the entire Pakistani Engineering community, I would like to thank PEC for all the efforts and appreciate them for envisioning 'as better as - the engineers'.

Engr. Syeda Masuma Fatima Zaidi

BS Electronics Engg. (SSUET, PK), MS Space Systems Engg. (UoG, UK)



UNITED
ENGINEERS &
CONTRACTORS
(PVT.) LIMITED

Perfection in all we build!



With Compliments From

Head Office: 92-P, Gulberg-II, Lahore. Tel: +92-42-35875113-4
Mob: +92-321-4459198 Fax: +92-42-35875116 Email: info@uecpvtltd.com

Karachi Office: Navy Housing Scheme Karsaz, PNS Bahadar, Karachi.
Tel: +92-21-39240360

Islamabad Office: House No. 13, A.K. Brohi Road, Sector G-11/1, Islamabad.
Tel: +92-51-2290239, 5823672

Eco-Friendly

LG LED LIGHTING



LED BULB



LED MR16



LED PAR16



STREET LIGHT



FLAT LIGHT



DOWN LIGHT



LED TUBE



ENERGY SAVING

Over 80% electricity saving compared to Incandescent bulb



ECO-FRIENDLY

No Mercury, Lead and UV light.



Up to 50,000 hr.

LONG LIFE

Up to 50,000 hours



LG

Contact us:

Muhammad Umair: 0333-3674434, Imran Zaidi: 0333-3674416
Office: 021-32624007-9

QUALITY OUR STRENGTH

ORDINARY
PORTLAND

SULPHATE
RESISTANT

ORDINARY
PORTLAND



PREMIUM BRAND
Rapid Setting

LION BRAND
Ordinary Portland



BLACK DIAMOND
For Block & Precast

BLAST FURNACE
Portland

DEWAN CEMENT LIMITED



Head Office:

Finance & Trade Centre, 2nd, 7th & 8th Floor, Shakra-e-Faisal, Karachi 75250, Pakistan.
Tel: +92 (21) 111 364 111 Fax: +92 (21) 35630884